



Kubota F3990 w/Bagger ROPS Cab

** Shown with optional equipment



Kubota F3990 Series ROPS Cab

This ROPS cab is designed and built to fit the Kubota F2690, F3990 with optional GCK72-F36 bagger installed.

Designed and built by:

Tektite Manufacturing Inc:

427 Buffalo Street

P.O. Box 639

Winkler, MB

R6W 4A8

Canada

PH: 204-331-3463

Fax: 204-331-4159

sales@tektite.ca

www.tektite.ca

One-year standard product warranty provided by Tektite.



DO NOT PROCEED FURTHER UNTIL YOU HAVE READ THE INFORMATION BELOW

- 1) Always wear personal protective equipment
- 2) A minimum of two people is necessary to safely install the cab
- 3) This ROPS cab is heavy. A lift assist device such as an overhead hoist or high lift forklift is required.
- 4) Ensure your work area is well ventilated. The installation requires the starting of the tractor which will produce dangerous carbon monoxide fumes.
- 5) Read through the entire installation manual first.
- 6) Follow the installation instructions in order.
- 7) Reading the operators manual prior to using the ROPS cab.





Tektite Manufacturing Incorporated thanks you for purchasing a Kubota F3990 series ROPS cab! Tektite has worked very hard to design and build this ROPS product and we hope that it provides you with many years of ROPS protection.

Tektite's ROPS products are designed to provide safe and dependable service during operation when they are properly maintained according to the instructions. Please read this installation manual carefully before installing and using this ROPS product.

The photos/illustrations provided in this manual may not provide all the detail needed and are for reference only.

All directions provided are from the reference point of the tractor seat facing the steering wheel. All left and right references are from this viewpoint.

For reference, please fill in the information below. This will assist your dealer in providing service for this ROPS. It is advisable that this information be provided to your insurance company as well in the event that the tractor is lost or damaged.

Mounting points for bagger onto 2-post ROPS will be modified to attach to cab.

Vehicle Model: _____

ROPS Serial Number: _____

Date of Purchase: _____

Dealer Name: _____



Parts List Standard Cab:

Description	Qty
180D bulb seal, 3" long	1
180D bulb seal, 6" long	1
180D bulb seal (Pinch welt shortened 1/2" each end), 6 3/4" long	2
180D bulb seal (Pinch welt shortened 1/2" each end), 8 1/2" long	1
180D bulb seal (Pinch welt shortened 1/2" each end), 5" long	2
180D bulb seal (Pinch welt shortened 1/2" each end), 4 1/2" long	2
Floormat, 3" x 5"	1
Bolt, Flange, 1/2" x 1 1/2", Gr. 8, YD	4
Nut, Flange, Serrated, 1/2", Gr. 8, YD	4
Fir Tree Fasteners	12
Under seat upholstery	1
Platform Support Bracket	L&R
Floormat, Platform	L&R
Bolt, Hex, 1/2" x 4 1/2", Gr. 8	2
Cab Lift Brackets	2
Wire Loop, 1/4", Yellow	2
Zip Ties, Standard	10
Left Bagger Mount	1
Right Bagger Mount	1
Bolt, Hex, 3/8" x 3"	6
Bolt, Hex, 3/8" x 1"	10
Nut, Flange, 3/8", YD	16
5/16" Washers, SLOTTED	2

Parts List Optional Components:

Heater

Description	Qty
Elbow Fitting, 3/8NPT x 3/8" Barb (Air Conditioned Cabs ONLY)	1
Straight Fitting, 3/8NPT x 3/8" Barb (Heat ONLY Cabs)	1
5/8" ID heater hose (3" long) with 5/8" to 3/8" reducer installed at one end	1
Hose clamp, HS-6	3

Air Conditioning

Description	Qty
Compressor REAR PORT	1
Compressor Bracket Mount	1
Over-flow Bottle Bracket	1



Compressor Tensioner Bracket	1
Alternator Mount Bracket (w/tube welded to one hole)	1
Alternator Mount Plate	1
GATES V-Belt, 10MM x 1095MM	1
V-Belt, 3/8" x 23"	1
Nut, Flange, 3/8"	5
Bolt, Flange, 3/8" x 2"	2
Bolt, Flange, 3/8" x 1 1/2"	3
Bolt, Flange, 1/4" x 1/2", YD	1
Washer, Flat, Fender, 5/16"	1
Red Wire, 10GA (1/4" yellow loop soldered one end)	12"
Red Wire, 16GA	12"
White Wire, 16GA	12"
Wire Wrap, 1" Long	5
Wire Loom, 3/8"	Two - 12"
Hose Clamp, HS-24	1
Bullet Connector, Female	1

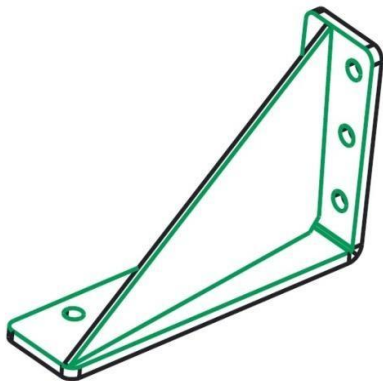

Left Bagger Mounting Bracket



Right Bagger Mounting Bracket



SLOTTED,
Washer, Flat, 5/16" x 1"
(MODIFIED)

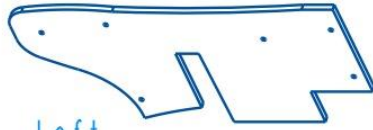

Left
Floormat

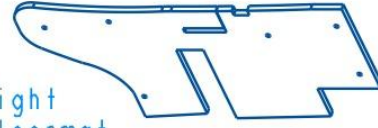

Right
Floormat

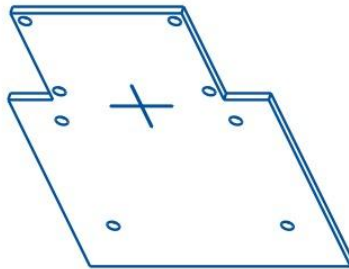

Under-seat
Upholstery



Overflow
Bottle Mount

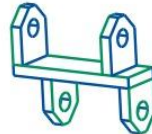

Compressor
Bracket

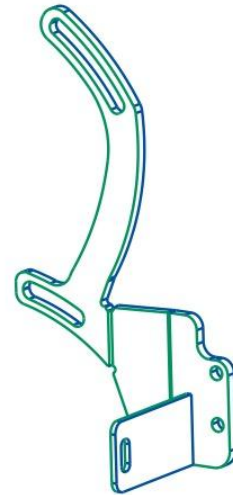

Compressor/
Alternator
Stiffener
Bracket



Left Platform
Support Bracket



Alternator
Mount Bracket



Right Platform
Support Bracket



Lower Radiator
Pipe Extension
Weldment



Alternator
Mount Plate

Park machine where access to an over-head hoist or forklift is available. Drop mower deck or lower front attachments before proceeding with any installation.

Disconnect the mower battery by unhooking the positive terminal.

ALL references to direction are based on sitting on the seat and facing forward.



If cab is equipped with air conditioning option, the following steps can be performed before the cab is installed onto the mower. There will be heater install parts done during AC installation!

Air-Conditioner Installation Instructions:

1. Remove the hose clamp fastening the air intake hose going directly to the turbo.

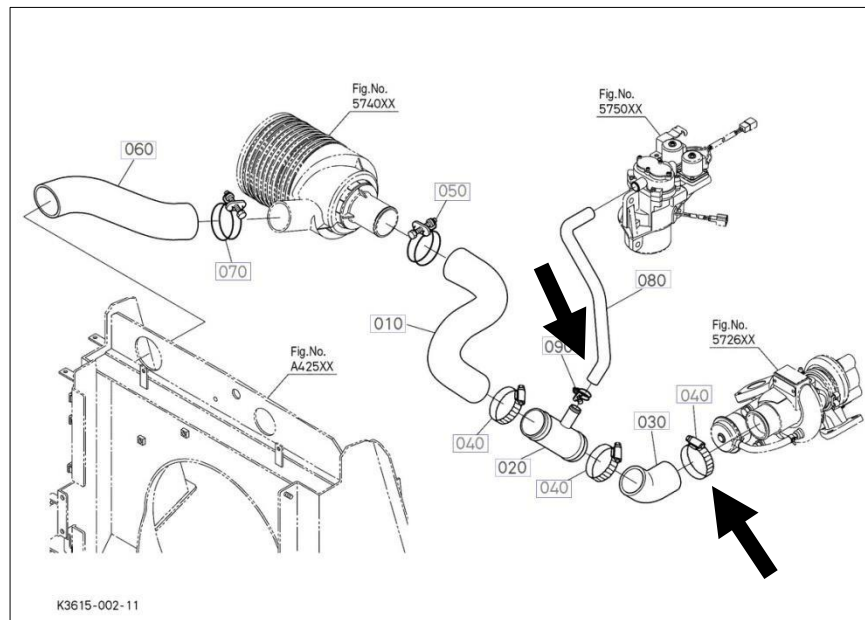

2. Slide the hose off the turbo.
3. Loosen the smallest hose clamp on the tee (20), then slide the small air intake hose that is going to the tee (20) shown on previous picture.
4. Remove entire air intake assembly from the tractor.
5. Locate the two hose clamps at the tee on the air intake assembly. Remove the clamps and reverse as they need to provide additional clearance for the compressor and alternator assembly. See photo below for orientation of the clamps after the air intake assembly is installed back onto the machine.

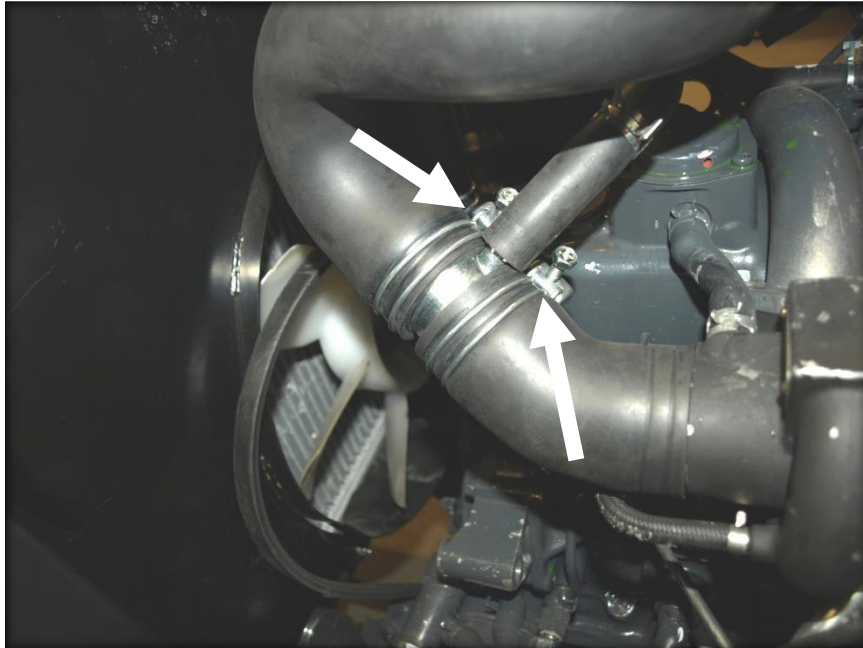

6. Un-bolt and remove the engine lift ear bracket on the left side of the engine. Save the fastener to be re-used later.

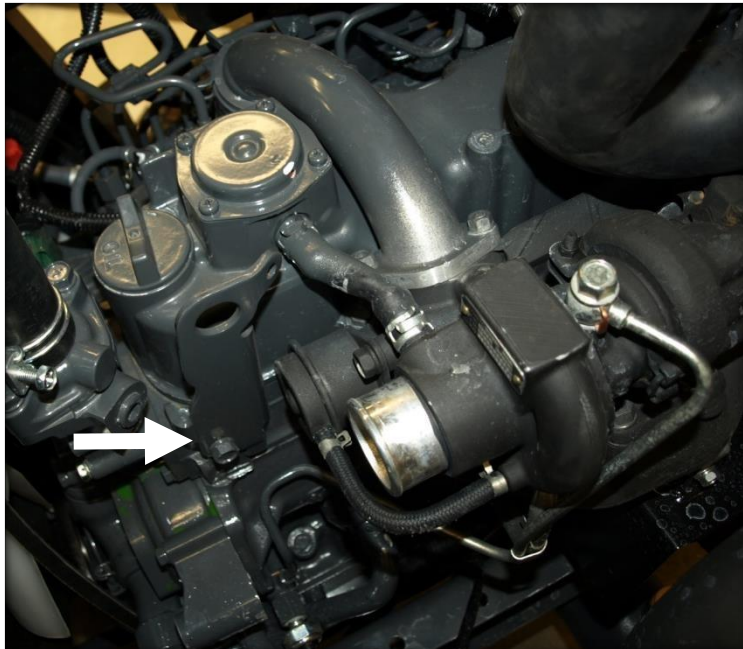

7. Lift the over-flow bottle off the mount bracket on the left hood shroud, and then un-hook the hose at the radiator. Take caution to prevent spilling engine coolant.
8. Un-hook the wiring harness plug and main power connector going to the alternator.



9. Loosen and remove the alternator tensioner fastener to remove belt tension, then slide main drive belt off the alternator.
10. Note the location shown in the next photo. Use a pry bar to modify the fan shroud to provide additional clearance for removing the main alternator fastening bolt.

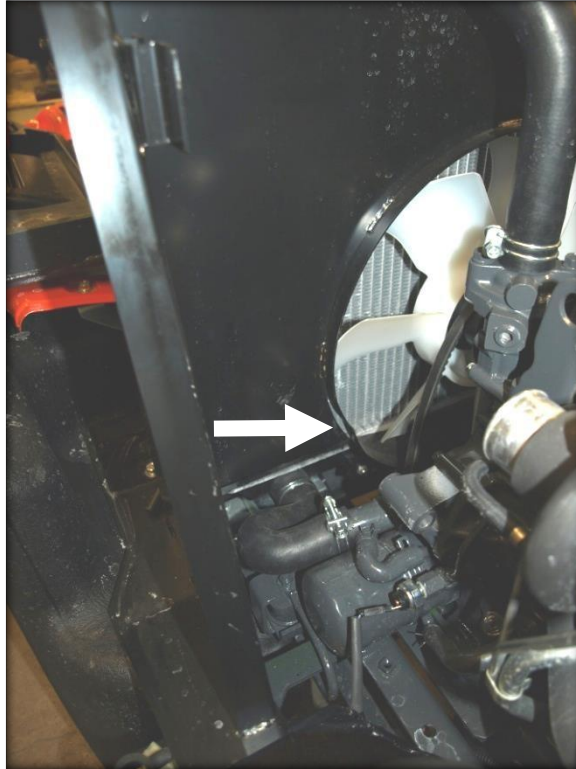

11. Un-bolt the tensioner bracket from engine and remove. Save fasteners to be re-used later.
12. Un-bolt the alternator from the bottom pivot and remove alternator from engine.
13. Locate the lower radiator water hose on the left side of the engine where it connects to the water pipe coming off the bottom of the water pump housing beside the oil filter. The hose makes a U at this location. Remove the hose and water pipe from the engine.

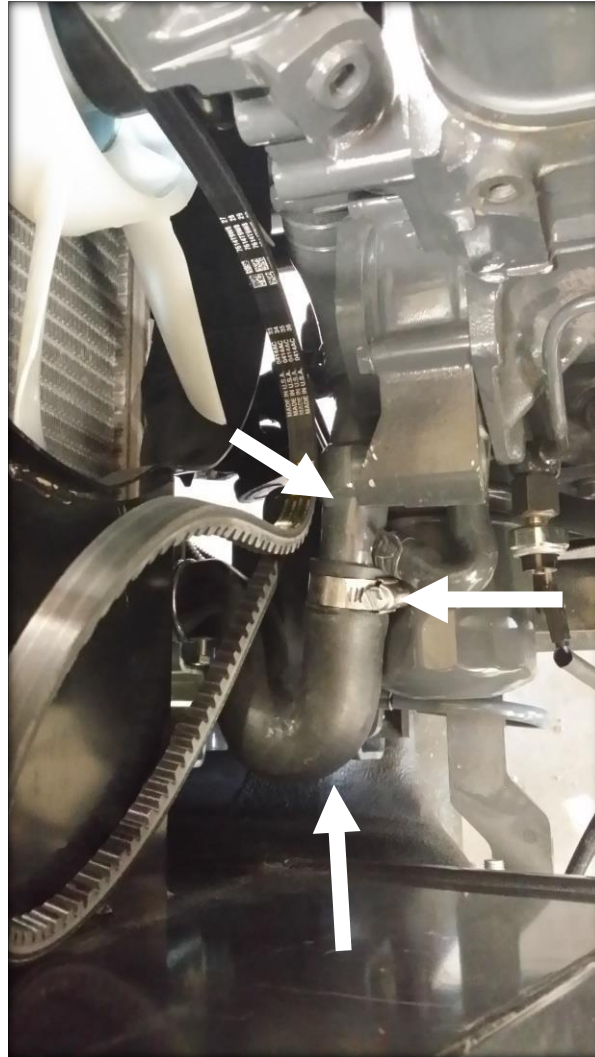

. Take the pipe and dent as shown in photo below to provide clearance for main drive belt.





. Re-install pipe onto engine along with the radiator hose. **The hose needs to be pulled away** to provide clearance for the main drive belt. Carefully push hose down until it is right against the oil filter. The hose moves easily, use caution while adjusting.

14. Remove the factory clamp that connects the hose going to the oil cooler tee. Slide hose outward so that the hose only overlaps about 3/4" onto the aluminum pipe. Take the provided HS-24 hose clamp and install onto hose and tighten so that the hose clamp is oriented as shown in the photo above.

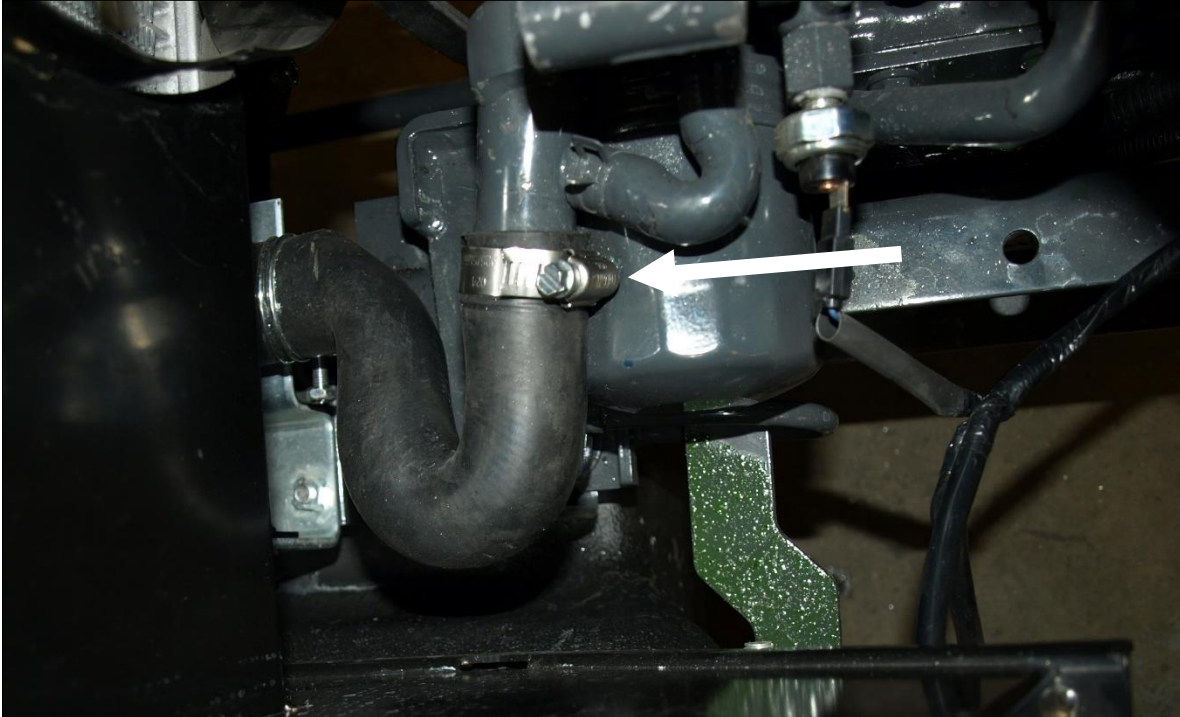

15. Un-bolt the main drive shaft on the engine.
16. Remove the factory drive belt.
17. Take the provided 10MM x 1095MM drive belt and slip it around the fan and onto the top fan pulley temporarily for now and under the main crank pulley.
18. Re-connect the main drive shaft.
19. Drain the engine coolant as part of heater installation procedure.
20. Take the compressor bracket tensioner and position it where the alternator tensioner and engine lift ear bracket used to be located. Use the factory hardware and LOOSELY attach the bracket to the engine at these three locations.

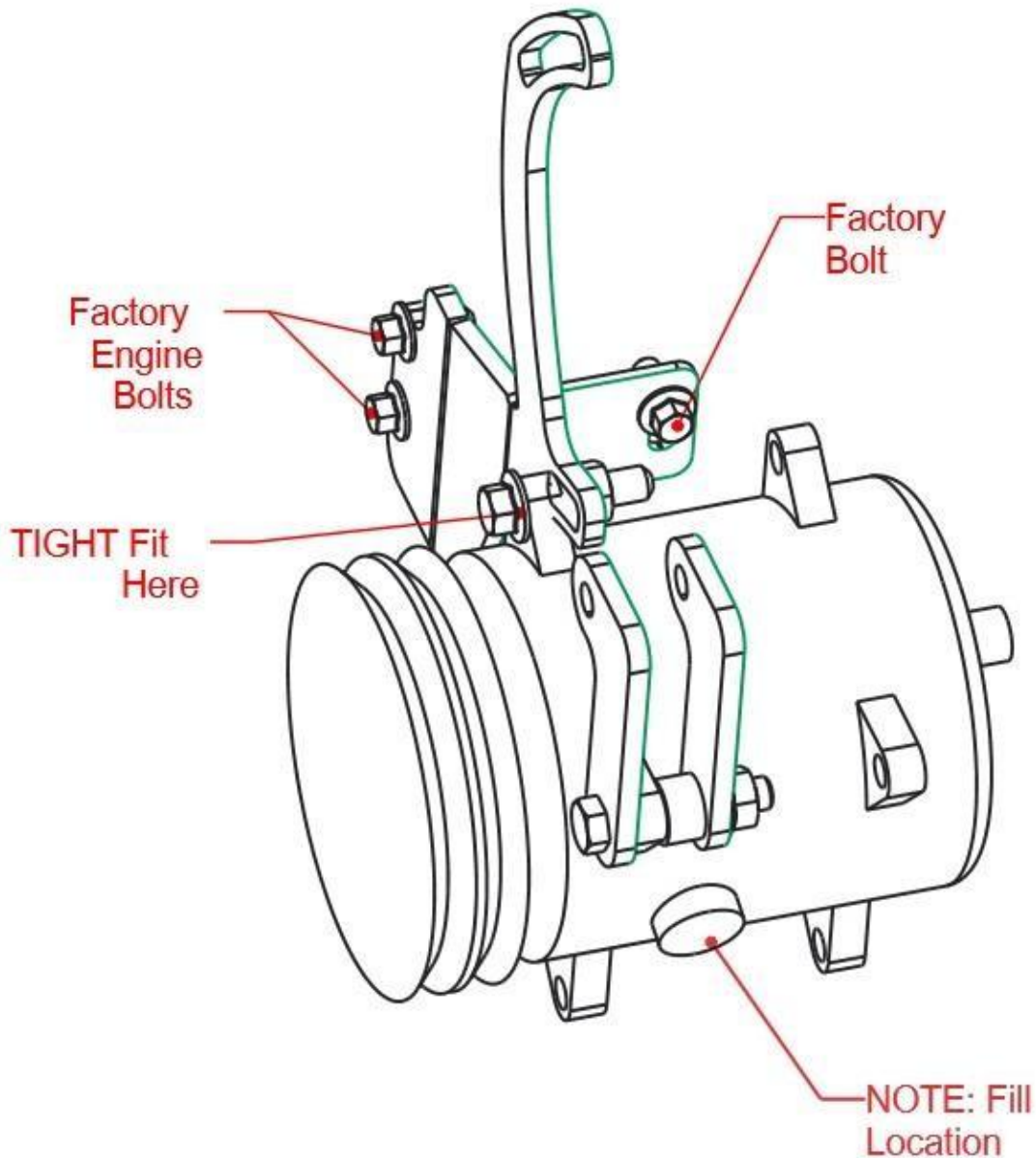

21. Take the provided compressor mounting bracket and slide over the alternator pivot casting on the engine block. Orientation is CRITICAL, the 2 5/8" outer spacing on the bracket needs to be OFFSET towards the REAR of the machine once bracket is installed, the spacing will be at the front. Use the factory hardware to fasten to engine, LOOSELY fasten only. NOTE, bolt is installed from the rear of the bracket, the nut is located on the front side.

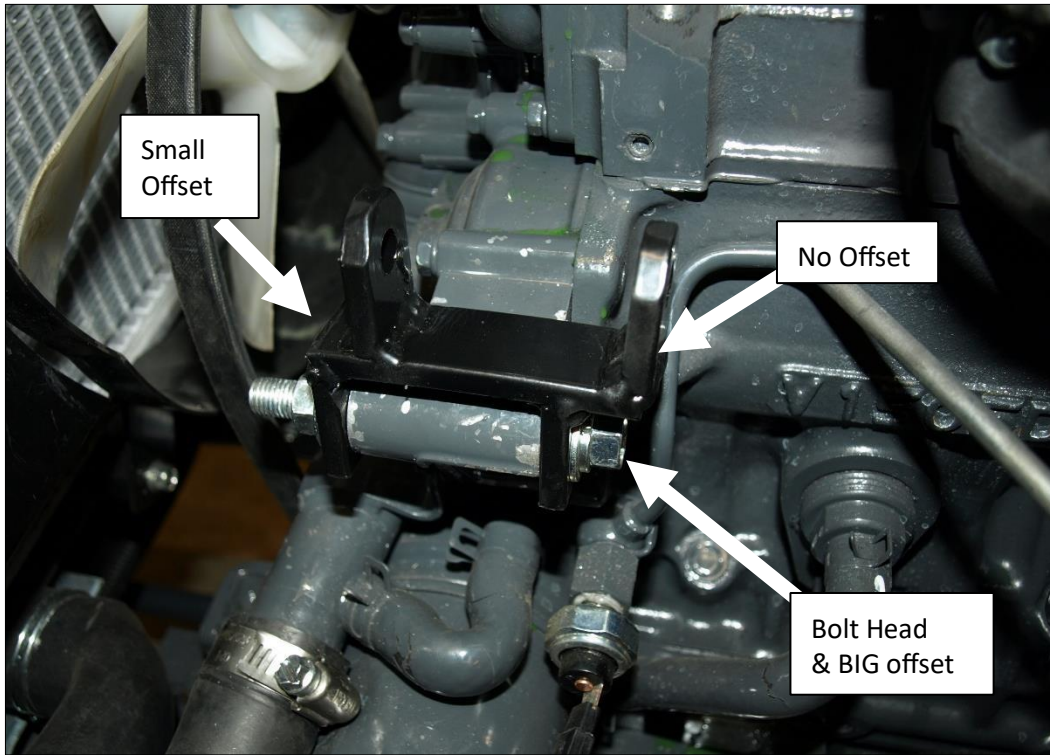

22. Take the compressor and slide over mounting ears on compressor bracket as shown in photo below. Take note of fill port location on compressor.

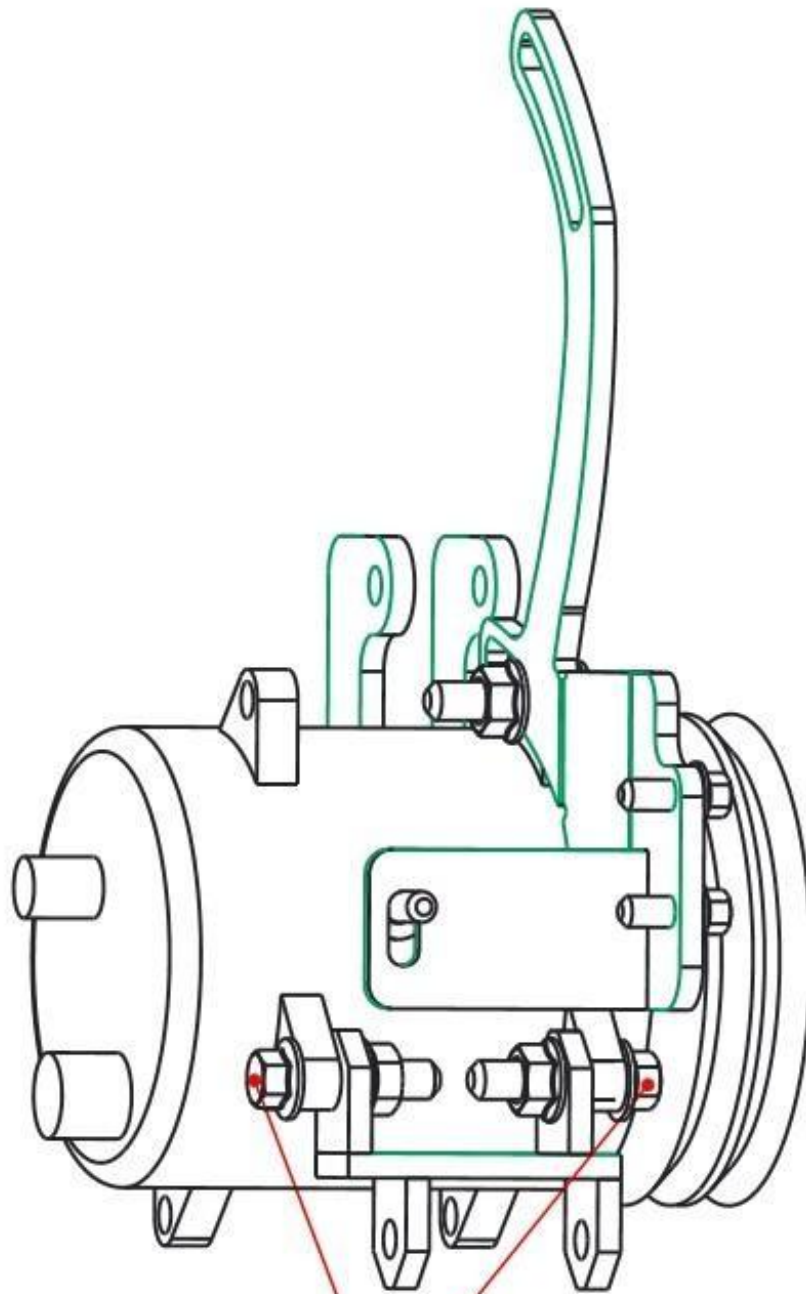

Note Bolt
Orientation

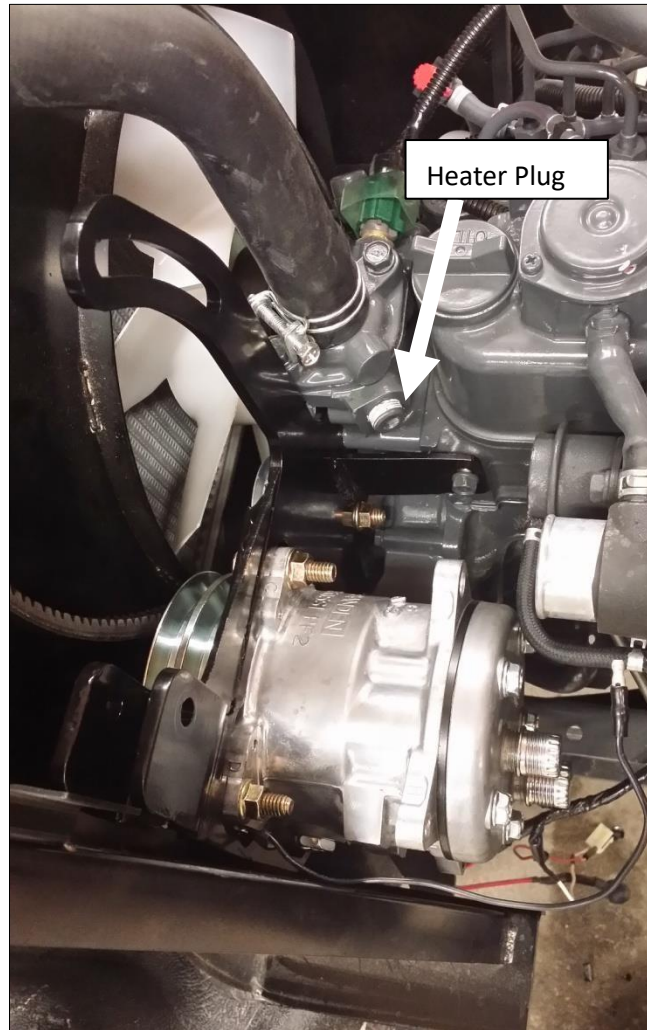

23. Remove the plug shown above in the thermostat housing.
24. Take the elbow 3/8 NPT x 3/8" barb fitting and install into open port. Use Teflon tape on the threads of the fitting to prevent water leaks. Fitting must be installed AFTER the compressor bracket is loosely positioned, and before the alternator is installed when maximum space is available to make installation easiest.

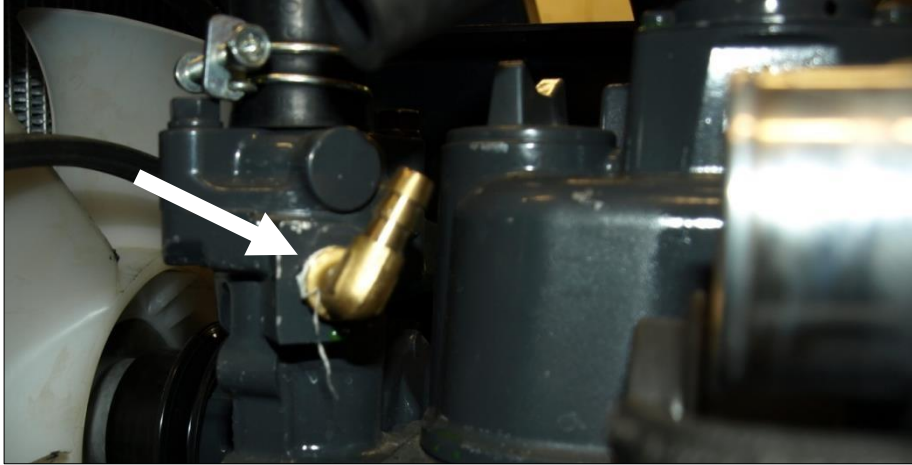

25. Slip the short belt provided on to the rear pulley of the compressor.
26. Take the alternator mount plate (NO TUBE) and position it on the front side of the top left compressor ear and slide the 3/8" x 2" hex bolt through it. Take the alternator bracket (WITH TUBE) and put the tube side against the compressor ear and loosely attach the alternator to the mount brackets.

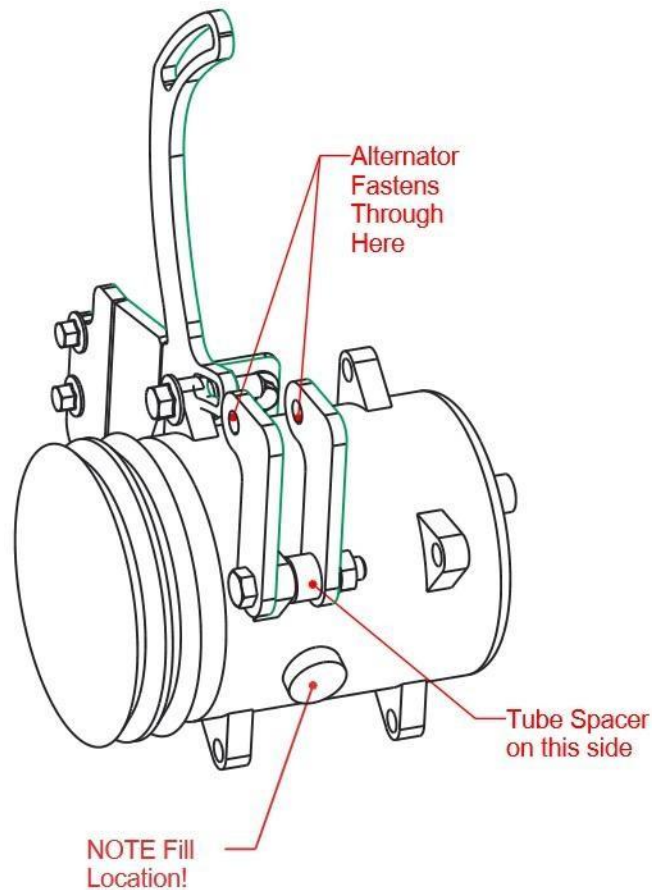



27. Slip the short belt onto the alternator and then slide the alternator pivot between the two plates installed earlier. Use the provided 3/8" x 2" bolt to fasten the alternator to the mount plates.
28. Slip the main belt over the front pulley on the compressor.
29. Take the original factory tensioner bolt for the alternator and fasten the alternator to the tensioner.
30. Tighten all brackets and apply tension to the belts. Start with the main drive belt.
31. Reconnect the main drive shaft.

If cab is equipped with heater, proceed with installation of heater fittings at this time:

33. Drain the engine coolant.
34. Locate the plug on the left side of the thermostat housing and remove. This will become the PRESSURE fitting. NOTE: Air conditioner equipped cabs require elbow fitting, heater only cabs use a straight fitting. Take the provided 3/8NPT x 3/8" barb fitting and install into port. Use a silicone sealant on the threads of the fitting to prevent water leaks. (A/C version shown).

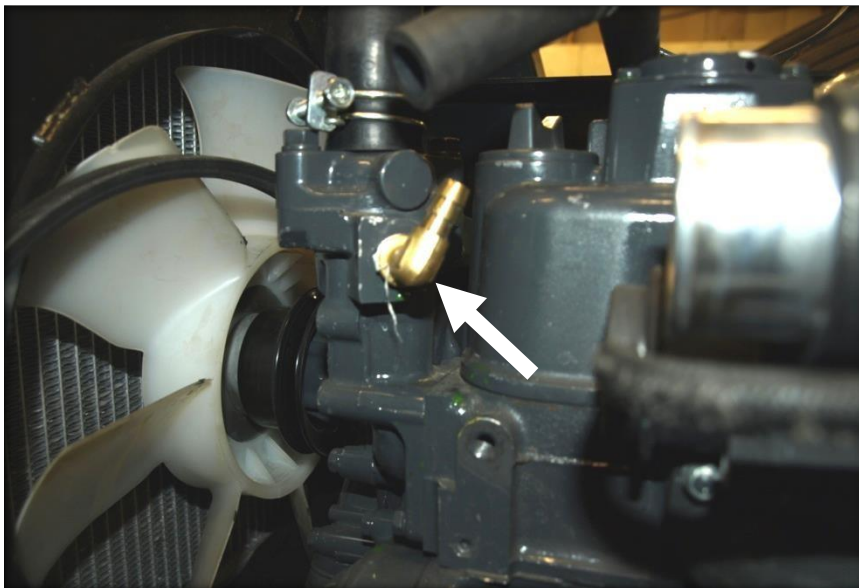

35. On the right side of the engine, locate the cap coming off the water pump. Remove the cap. This will become the SUCTION fitting. Take the 5/8" ID hose with a 3/8" reducer installed and slide onto the fitting. Use the provided HS-6 hose clamp to secure the 5/8" ID hose. Ensure that the clamp is tight.

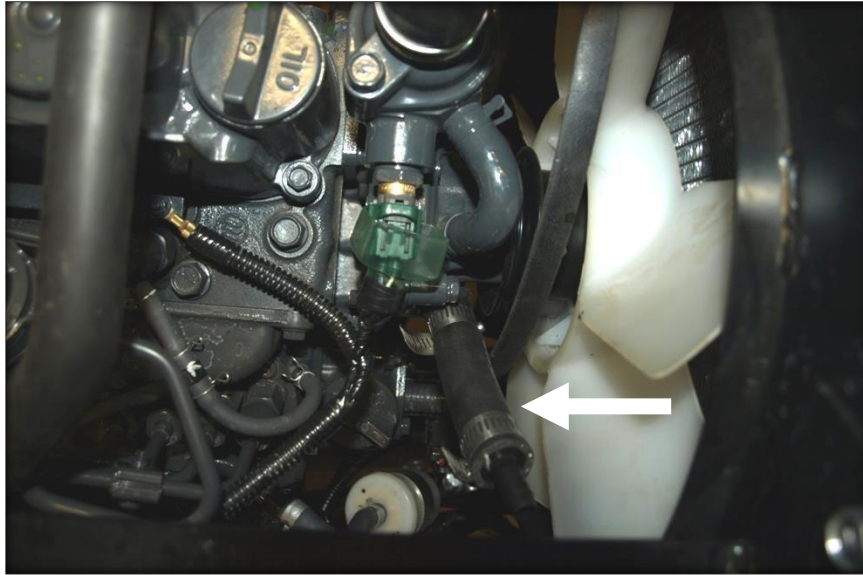

Proceed with Grass Catcher Modification

1. Support the grass catcher sub-frame mount at the rear of the machine to remove the 2-post ROPS.
2. Un-bolt and remove the grass catcher sub-frame (4 fasteners per side) from the 2-post ROPS.
3. Where the vertical bent 1/4" plate meets the 2" x 1" tube, mark and cut the tube as shown below. Cut both mount plates off sub-frame.

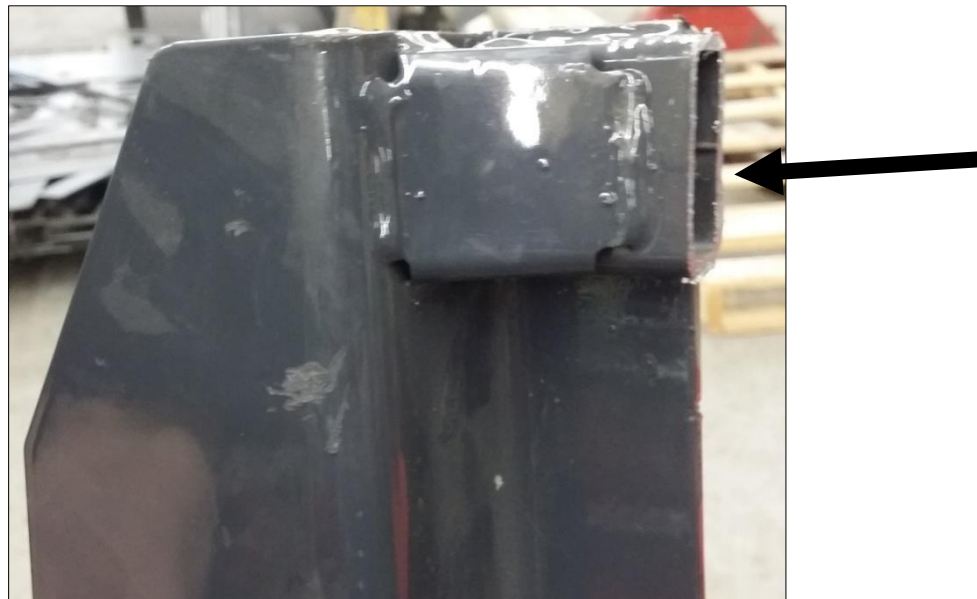
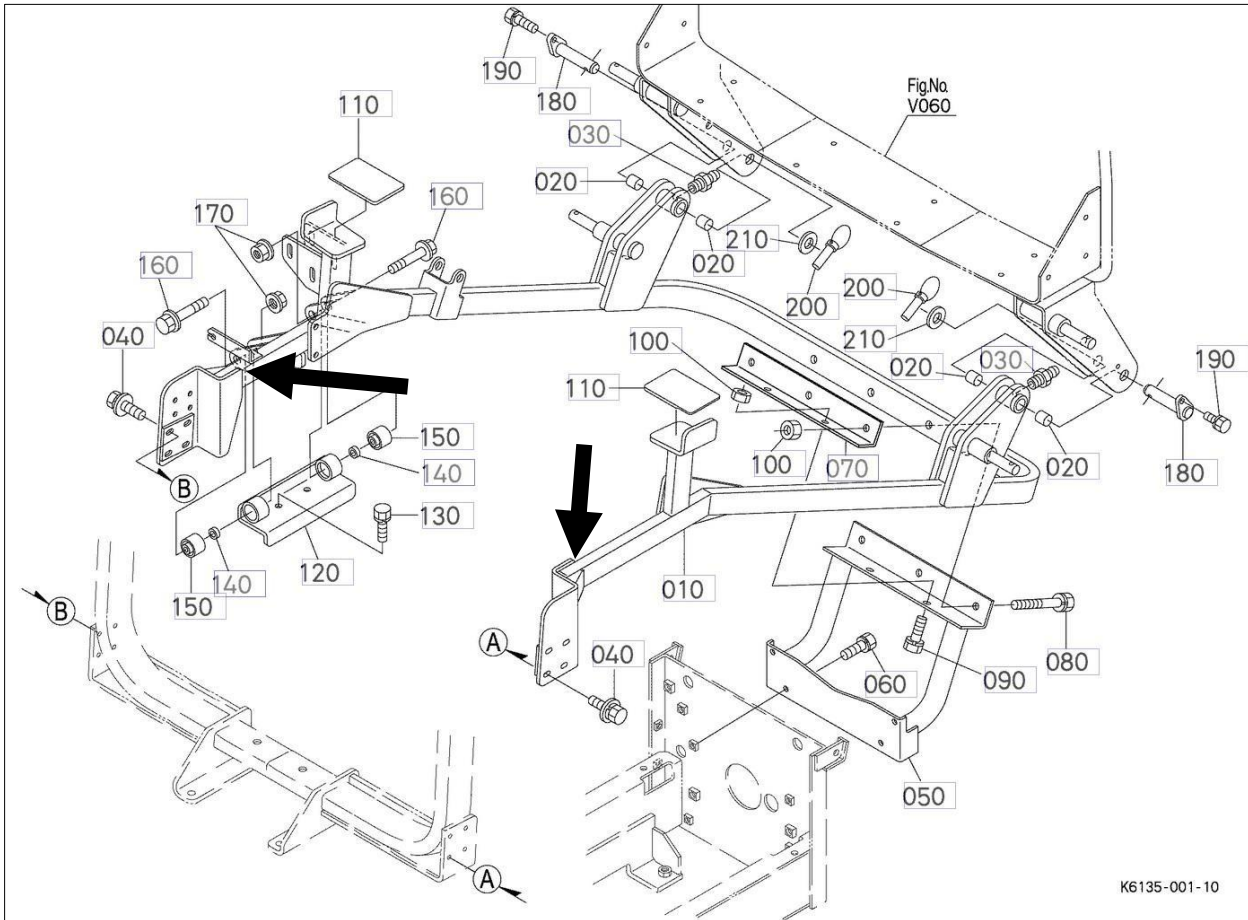

4. Keep sub-frame supported while cab is installed. Tip open grass catcher hopper to assist the balance of the assembly.



5. Un-bolt and remove the dump activation bracket assembly from the right 2-post ROPS mount and disconnect spring for now at the rear of the lever. The lever will need to be modified once installed onto the cab.

Proceed with cab installation.

36. Un-bolt the four M12 fasteners and remove the 2-post ROPS from the chassis. Save the fasteners for re-installation later.
37. Un-bolt and remove the tractor seat from the platform.
38. Remove the driver side floor pad from the operator platform. Ensure that the buttons retaining it are completely removed from the foot platform.
39. Remove the right-side floor pad from the operator platform as well. Ensure that the retaining buttons have been completely removed before proceeding.

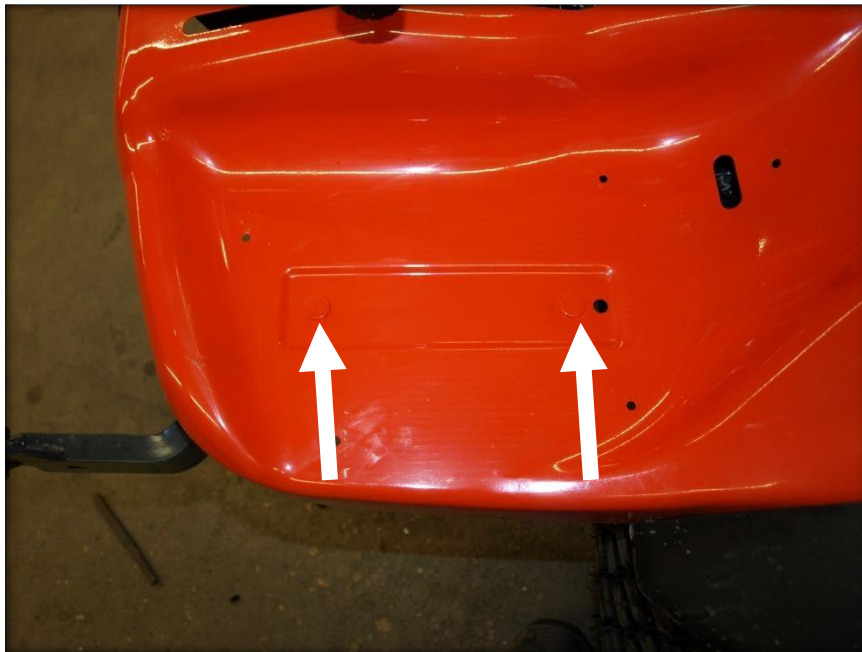

40. Note the two raised flat-head bolts in the left foot platform area. Remove both nuts from underneath the platform. Mark the centre of the two bolts, centre punch, then drill 1/2" through the platform.
- 40a. Remove the two bolts shown in the photo below.

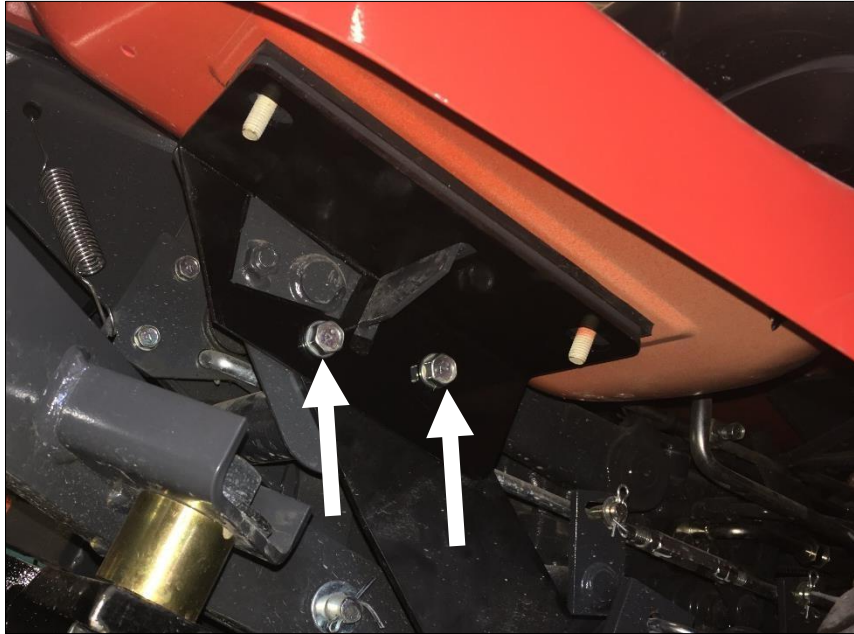

41. Note the two raised flat-head bolts in the right foot platform area. Remove both nuts from underneath the platform. Mark the centre of the two bolts, centre punch, then drill 1/2" through the platform.
42. Take the provided 3" long piece of 180-degree bulb seal for the opening at the brake lock pedal. Slide the rubber onto the outside edge of sheet-metal in the slot to close up pedal gap.

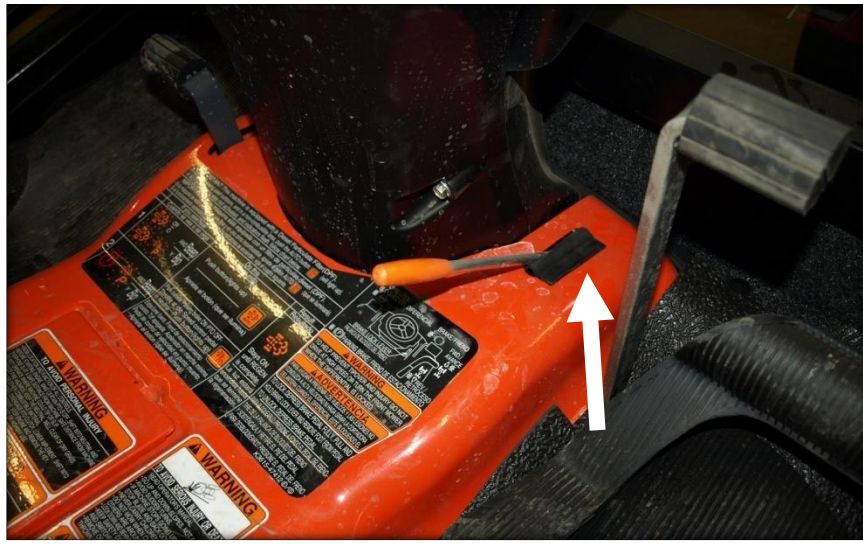

43. Take the provided 6" long piece of 180-degree bulb seal for the diff lock pedal opening. Slide the rubber onto the outside edge of sheet-metal in the slot to close up the pedal gap.



44. The console on the right side of the machine needs to be removed. Remove the handle endcaps from all the controls that are installed. Remove the retaining fasteners, then remove the black plastic shroud from the machine.
45. Use the photos below as reference for installing the five bulb seal parts, photos are from underneath the foot well.

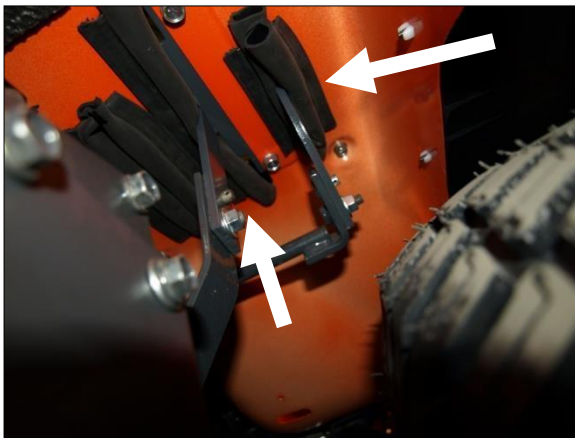

46. For the front left slot, take the two 6 3/4" bulb seals. Slide one rubber onto each side of the slot.
47. For the middle slot, take the 8 1/2" bulb seal and slide it onto the left edge of the sheet metal.
48. On the right front slot, take both pieces of 5" bulb seal and slide onto each edge of the slot.
49. For the rear left slot, use both pieces of 3 1/2" bulb seal, and install one onto each side of the slot.



50. For the right rear right slot, take both pieces of 4 1/2" bulb seal and slide the seals onto each side of the slot. For the left rear opening, if mower is equipped with front hydraulics, it will be necessary to slot the 3" x 5" floor-mat piece, otherwise just glue into place. Re-install the black console shroud.
51. Un-bolt seat frame fasteners from platform, disconnect seat kill switch, and then remove seat assembly.
52. Take the platform upholstery and position onto the seat platform steel panel, aligning holes in upholstery with fastener holes in the steel panel. Use a high strength aerosol glue, 3M High Strength 90 is recommended, and glue the upholstery down onto the steel panel.



53. Return to the cab to install lift brackets next. To remove the gas shock on the left cab door, slide a flat screwdriver underneath the small clip on the end cap that must be pulled UP order to pop the shock off the ball stud. **The shock will release very easily when this is accomplished.** Lift the door assembly straight up and off the cab and put aside for now.



54. Un-hook the gas shock on the right cab door using the same procedure. Lift the door assembly straight up and off the cab and put aside for now.
55. Take the 1/2" x 4 1/2" hex bolt and one of the lift brackets and locate the weld nut located at the top, rear of the left door opening. Position the lift bracket tube on centre of the weld nut, against the outer plate on the cab, and fasten the hex bolt to the cab. Repeat for the right door opening lifting point.



56. Use caution to prevent the roof from getting marked up while connecting the two lift brackets with a lift strap or chain by placing soft towels/shop rag between chains and roof. Create a centre lifting point and attach to an over-head hoist or forklift and prepare to the lift the cab.
57. Remove the fasteners on the front and rear brackets that attach cab to the shipping pallet.
58. Loosen the 5/8" isolator fasteners on the rear bracket and front brackets to allow a little bit of adjustment during the installation procedure.
59. Lift cab straight up and off the shipping pallet.
60. Position the cab directly over the mower and slowly lower down onto the machine platform. The rear bracket will go exactly where the 2-post ROPS mounted to the chassis, and the front brackets will go to the holes drilled earlier in the foot well areas.
61. Re-use the 2-post ROPS hardware for the rear bracket fasteners.
62. Take the provided 1/2" x 1 1/2" flange bolts and flange nuts for the left and right front bracket fasteners. Insert bolt through top of platform. Take the LEFT platform support and position underneath the platform with the 1/2" bolts through the top. The factory bolts, removed earlier, for the support will go through the other holes in the bracket.



62b. Take the provided 1/2" x 1 1/2" flange bolts and flange nuts for the right front bracket fasteners. Insert bolt through top of platform. Take the RIGHT platform support and position underneath the platform with the 1/2" bolts through the top. The factory bolts, removed earlier, for the support will go through the other holes in the bracket. If front hydraulics are present, that plate will be on the outside of the support bracket.



63. Once all fasteners have been started, the rear and front bracket fasteners to the chassis can receive 102 ft-lbs of torque. The cab isolator fasteners can receive 240 ft-lbs of torque.



64. Carefully remove the cab lift straps or chains from the over-head hoist or forklift.
65. Un-bolt and remove the lift brackets. Store the fasteners and lift brackets if you will be removing the cab in the future.
66. Re-install the mower seat with factory hardware.
67. Route the electrical harness into the hood area.

A/C Equipped Cabs ONLY. The alternator wire harnesses need to be lengthened for the new alternator location on the engine. Take the main power wire to the alternator and snip the wire loop off. Take the provided 10GA red wire with 1/4" loop already installed and solder to the end of the wire that has just been cut. Use the provided wire wrap and cover the soldered connection. Re-connect main power wire to alternator. Take the white connector end first and cut the blue-red 16GA wire near the end, 2" away from the connector. Take the provided 16GA red wire and solder the wire into the harness. NOTE: Solder the cab orange wire to this wire as well, it is the switched terminal on the alternator. Use the provided wire wrap and cover the soldered connections. Take the white wire going to the other connector and cut approximately 1" away from the connector. Take the provided 16GA white wire and solder the wire into the harness. Use the provided wire wrap and cover the soldered connections.

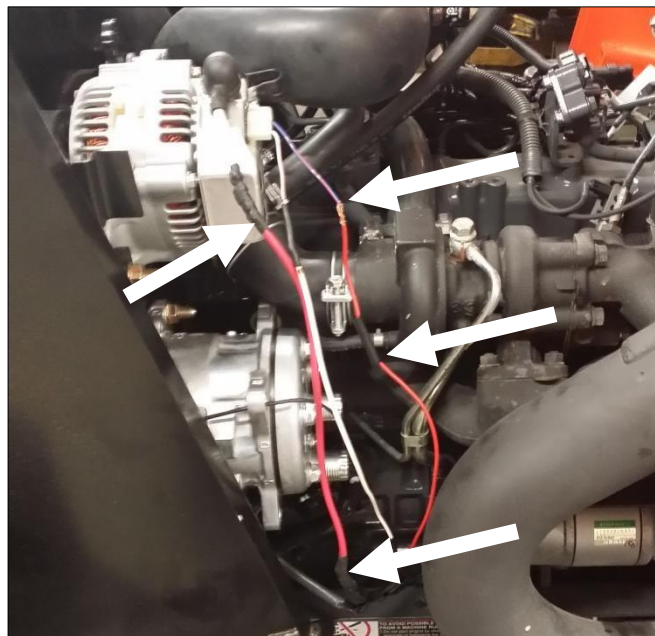

A/C Equipped Cabs ONLY. Take one of the provided wire looms and install the 16GA red and white wires together inside.



A/C Equipped Cabs ONLY. Take the remaining wire loom and install the 10GA red wire inside of it. Use zip ties to retain the harnesses together in the loom.



ALL Cabs. Connect the black 10GA wire to the tractor ground shown in the next photo at the rear mount bolt of the starter. It will be necessary to remove the front fastener and loosen the rear fastener on the starter cover to get full access. Shorten wire, if necessary, then solder the provided loop to the wire and connect to the ground.



HEATER ONLY Cabs. Connect the red 10GA wire to the 12V power source on the alternator as shown below. Shorten the wire, if necessary, then solder the provided 1/4" loop to the wire and connect to the power source.

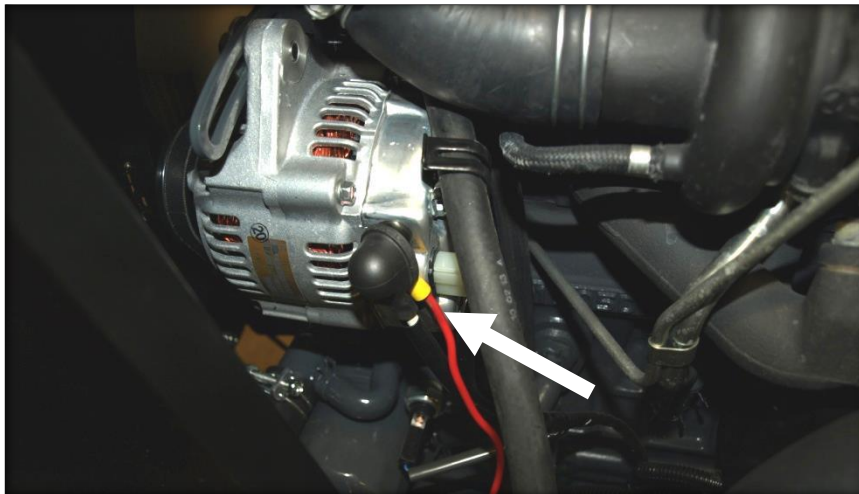

HEATER ONLY Cabs. Connect the orange 16GA wire to a key switch activated source on the alternator, the blue-red wire. Splice directly to this wire and solder the connection directly.

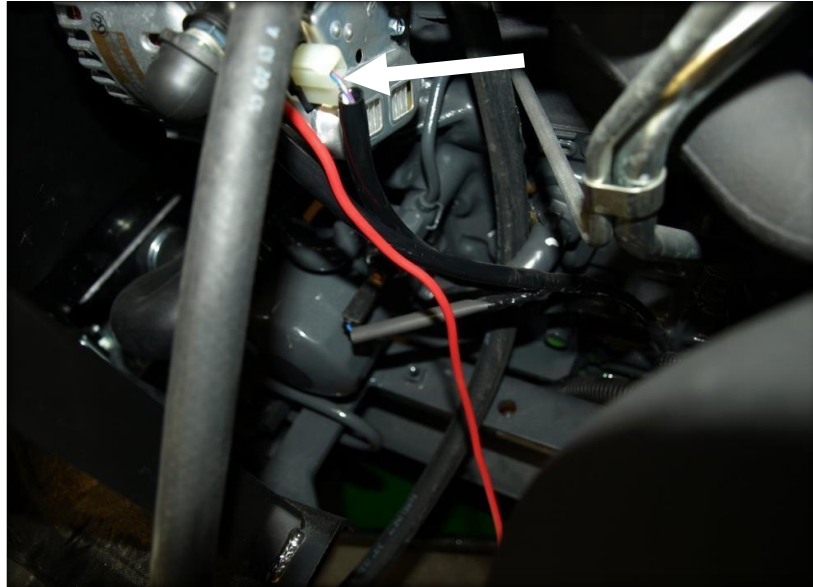

73. Take the left floor mat panel and position it on the operator platform over the front left bracket. Use the provided fir tree fasteners to secure the floor mat to the sheet metal through the existing sheet metal holes. Use a hammer and hit the floormat on the heads of the 1/2" bolts to remove the matting above the bolt head. See below. This will help retain floormat and clean up the install.

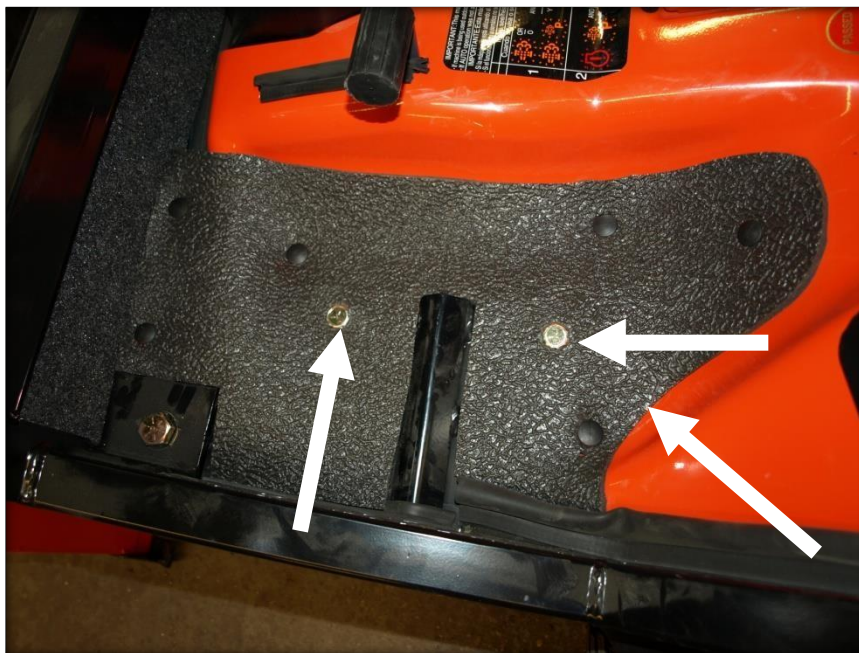

74. Take the right floor mat panel and position it over the right front bracket on the opposite side. Use the remaining fir tree fasteners to secure the floor mat to the sheet metal through



the existing holes in the sheet metal. Use a hammer and hit the floormat on the heads of the 1/2" bolts to remove the matting above the bolt head. See below. This will help retain floormat and clean up the install.

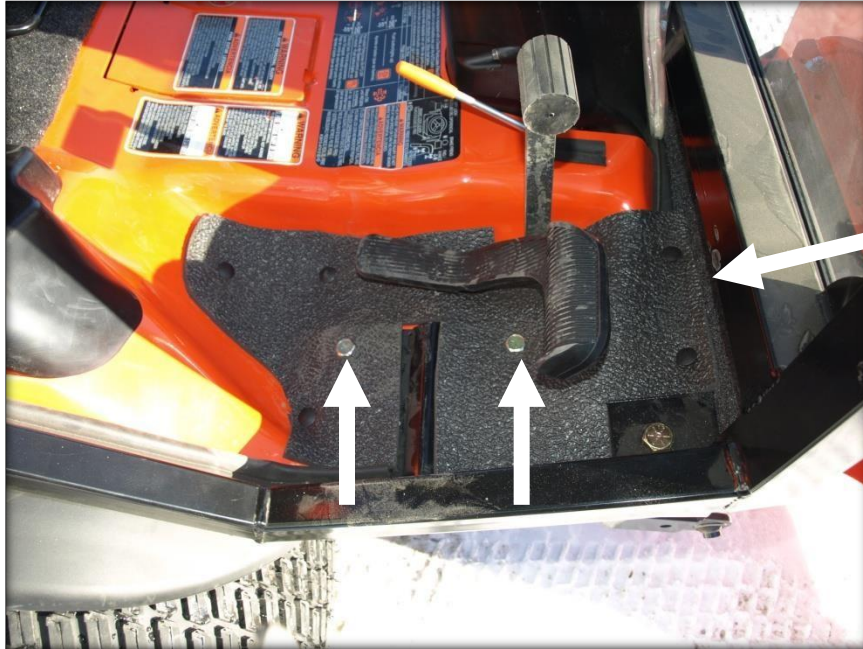

75. Use a black silicone sealant to seal the cab to the mower platform to close up gaps between the seals and the platform.

Heater installs continued.

76. Locate the heater hoses at the rear of the cab (AC cabs have heater hoses on the right). The hose closest to the glass is the PRESSURE side hose.

77. Route the pressure hose down from the back of the cab and up into the engine bay.

78. Ensure you will have adequate length of hose to get to pressure fitting on LEFT side of engine. Make sure that moving parts or very hot areas will not contact hose. Cut the hose if necessary and use the provided HS-6 hose clamp to connect hose to the fitting.

79. Route the suction hose down with the pressure hose into the engine bay. Ensure the hose will not interfere with any moving parts or very hot areas of the engine. Shorten the hose, if necessary, then connect hose to the open port installed earlier on the RIGHT side of the engine with the provided HS-6 hose clamp.

80. Using the provided zip ties, secure the two hoses to the engine to prevent them from moving around.



81. Make sure all the fitting connections to the engine are tight and secured to the tractor.
82. Re-fill the engine antifreeze.
83. Please note, carbon monoxide and engine exhaust gases are very deadly, ensure adequate fresh air ventilation while purging air from the coolant system. Start engine and move mower if necessary. Turn the cab climate control knob for the heating system to maximum heat and then start running the engine at high RPM to heat the system. The thermostat on the tractor will need to cycle to remove any air locks from the cooling system. Re-fill the engine coolant as is needed. Turn cab fan to maximum speed. The heat coming out of the cab louvers should be very HOT when the coolant system has been properly purged of air.
84. Go to the right front corner of the hood on the F3990. Pull back the pinch welt. Mark a 3/4" x 3/4" corner and cut off. Re-install pinch welt, cut off end and install onto angled side.

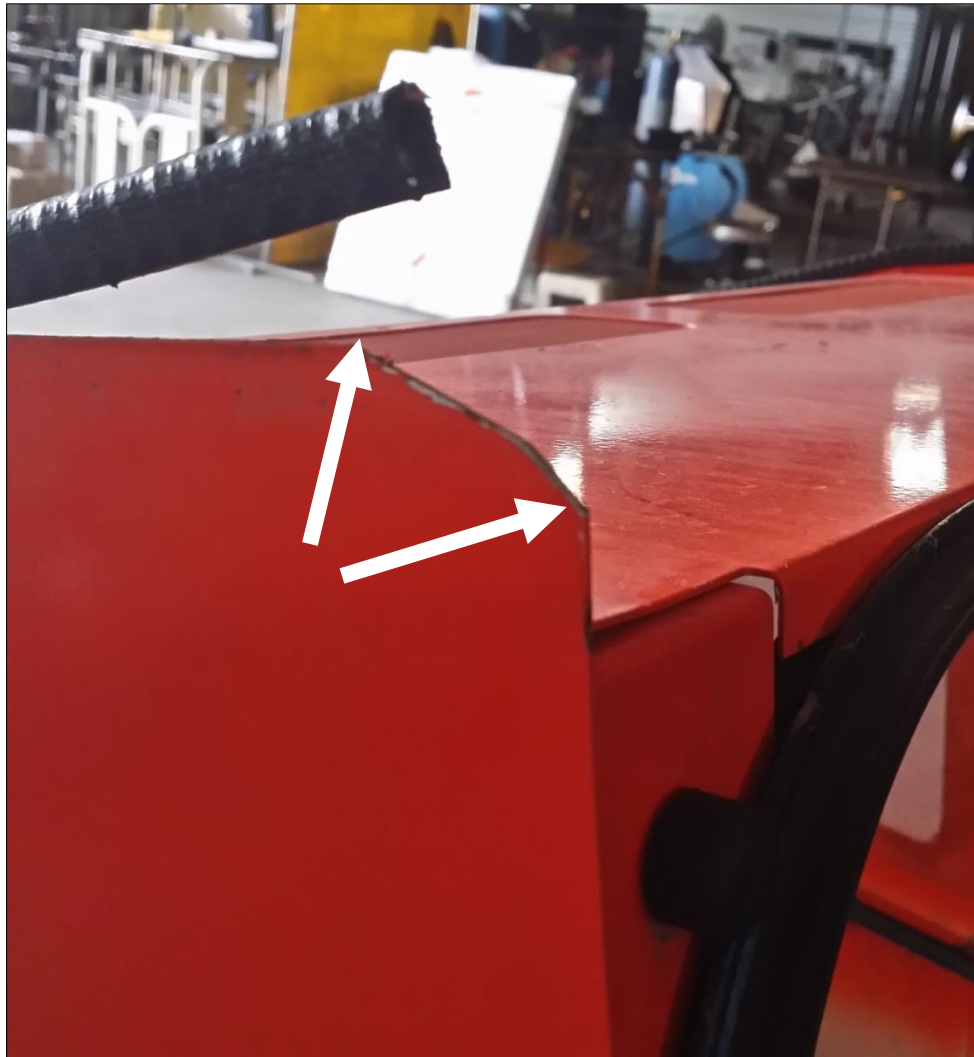



Grass Catcher install continued.

5. Take the left grass catcher bracket and fasten to the outside left cab mount plate. Use provided 3/8" x 1" hex bolts and flange nuts. Tighten bracket.

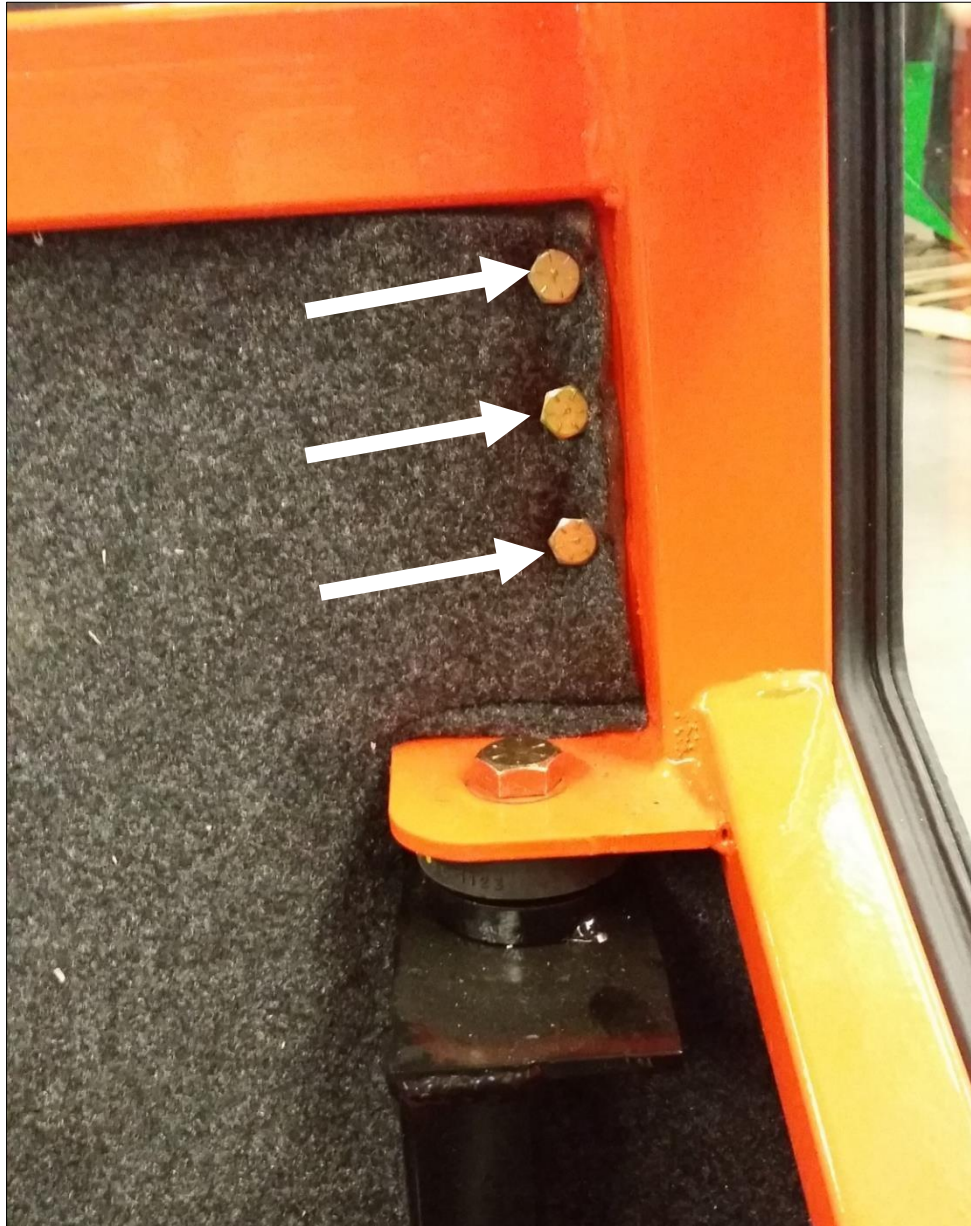

6. Take the right grass catcher bracket and fasten to the outside of the right cab mount plate. Use 3/8" x 1" hex bolts and flange nuts provided and tighten bracket into place.

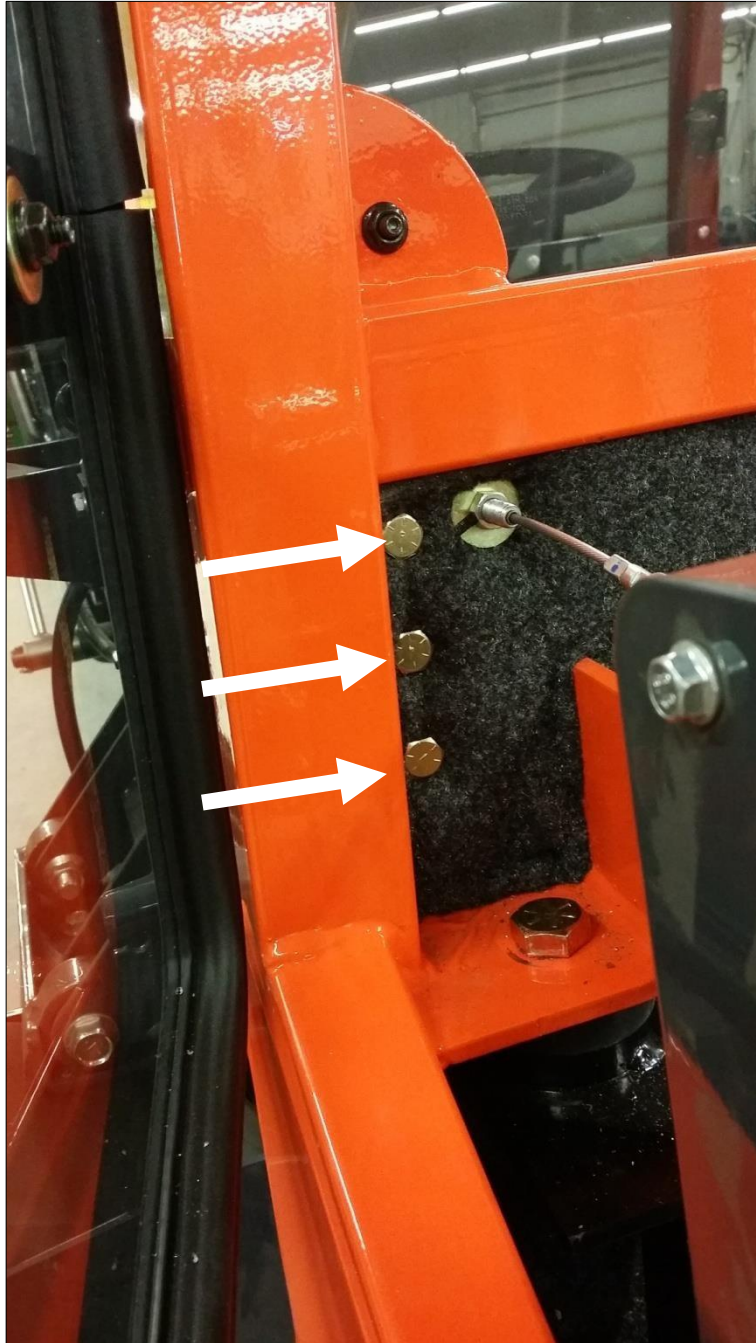

7. Position the grass catcher sub-frame tube underneath the brackets installed on the cab. Centre tube on the mount plate as best as you can and clamp bracket to the sub-frame. Mark the three holes in each mount plate onto the tube. Drill three 3/8" holes through 2" x 1" tube of sub-frame on each side.

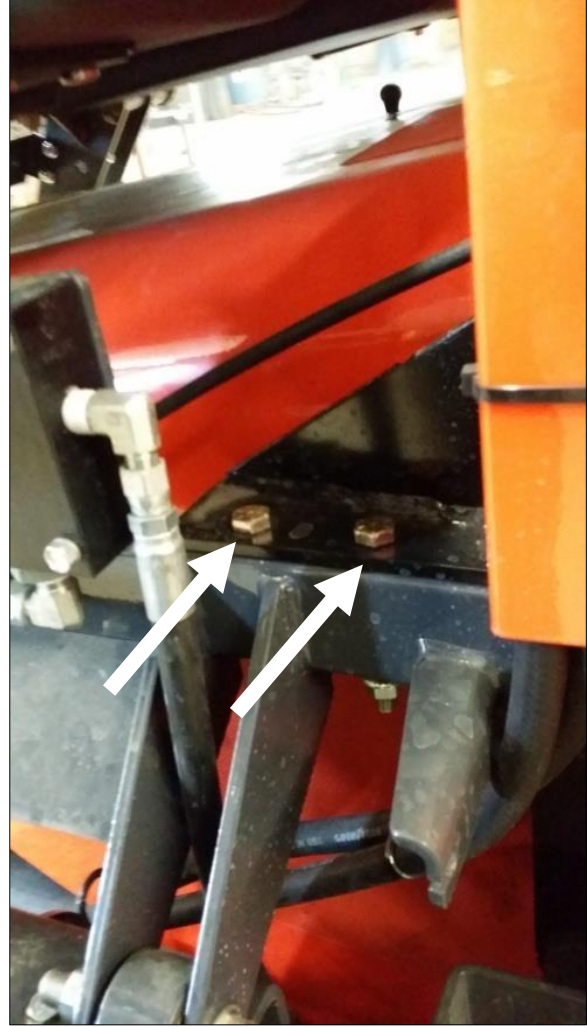
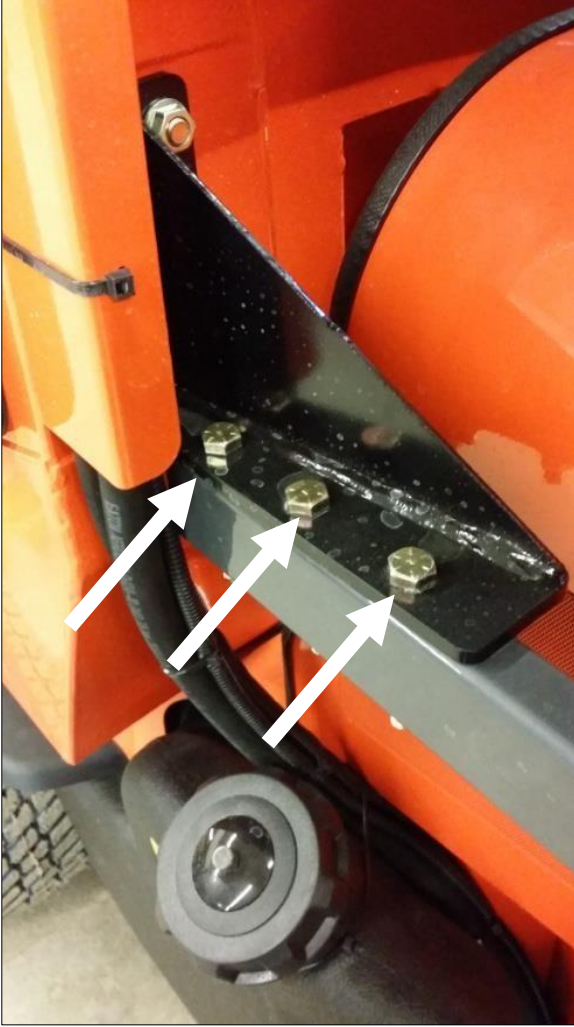

8. Use the provided 3/8" x 3" hex bolts and flange nuts and bolt the brackets to the bagger subframe. Tighten all fasteners.
9. Take the lower support fastener and isolator on the right side and bolt to the right bagger mount bracket with the factory hardware.

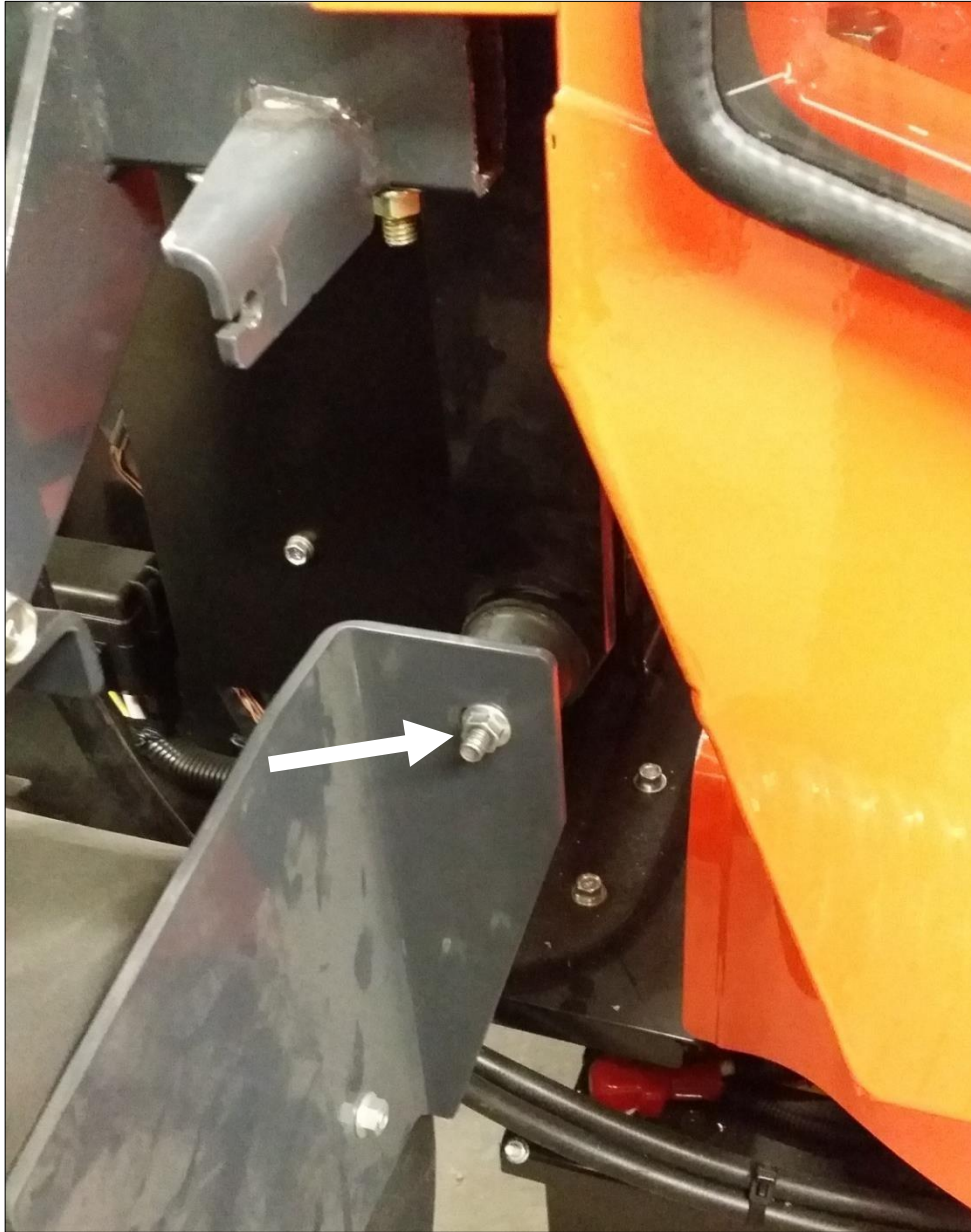

- 10 Take the dump activation lever box and fasten to the mount on the inside of the cab. Use the provided 3/8" x 1" hex bolts and flange nuts. Angle the mount back as far as you can.

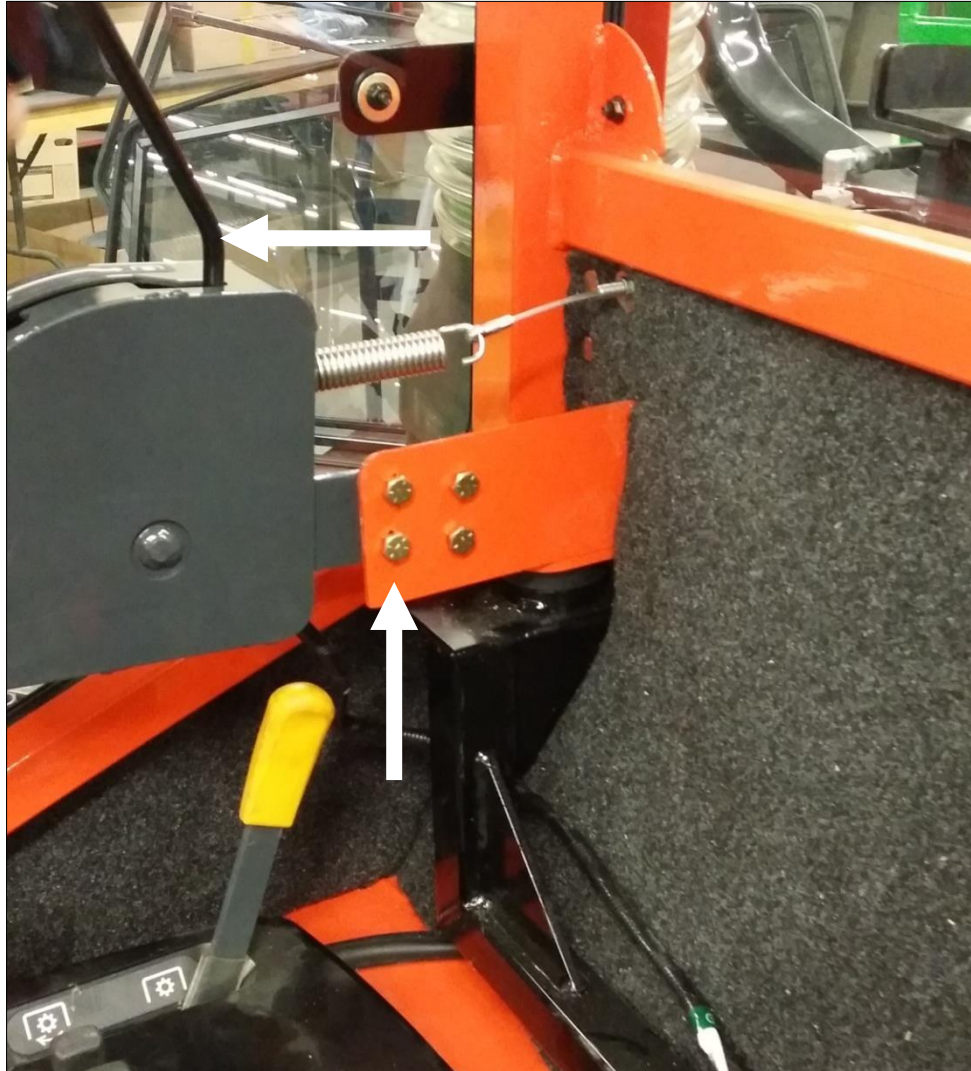

- 11 The lever will need to be bent inwards to provide sufficient clearance for the door and b-post of the cab.
- 12 Take the clutch wire and send it through the 5/8" hole in the rear cab mount plate on the right side. Slide it through the slotted flat washers on the inside and outside of the cab. Connect onto the spring on the lever control, and then tighten the clutch wire to the cab with the factory nuts on the cab.



- 13 Use the provided zip ties to secure the cable harness going to the lever control to the cab mount plate.

Air Conditioner install continued.

85. Locate the air conditioner hoses and clutch wire at the left rear corner of the cab. Take the hoses and wire and route around the fuel tank and then up and into the engine bay.
86. Ensure the O-ring is seated in the fitting, then install the # 10 fill port fitting onto the rear of the compressor. The fitting must come in from below.
87. Ensure the O-ring is seated in the fitting, then install the # 8 fill port fitting onto the rear of the compressor. The fitting must come in from below.
88. Take the clutch wire, shorten, if necessary, then install the female bullet connector onto it. Plug onto the male bullet located on the compressor.
89. Take the over-flow bottle removed earlier and swap the two hoses.



90. Remove the pinch welt weather stripping on the right-side top shroud of the radiator housing. Measure 4 3/4" from the top and 3/4" from the bend. Drill a 1/4" hole at this location.



91. Take the 1/4" x 1/2" flange bolt, 5/16" fender washer, and the overflow bottle bracket. Put the fender washer on the inside, between the weld nut and the radiator shroud panel, then fasten bracket onto the radiator shroud.
92. Take the overflow bottle and slide it into the mount provided. NOTE: it will be a tight fit to the radiator shroud.



Kubota F3990 Series Cab

** Shown with optional equipment



Kubota F3990 Series Cab

This ROPS cab is designed and built to fit the Kubota F2690 and F3990.

Designed and built by:

Tektite Manufacturing Inc:

P.O. Box 639

427 Buffalo Street

Winkler, MB

R6W 4A8

Canada

PH: 204-331-3463

Fax: 204-331-4159

sales@tektite.ca

www.tektite.ca

One-year standard product warranty provided by Tektite.



Tektite Manufacturing Incorporated thanks you for purchasing a Kubota F3990 series ROPS cab! Tektite has worked very hard to design and build this ROPS product and we hope that it provides you with many years of ROPS protection.

Tektite's ROPS products are designed to provide safe and dependable service during operation when they are properly maintained according to the instructions. Please read this operator manual carefully before using this ROPS product.

The photos/illustrations provided in this manual may not provide all the detail needed and are for reference only.

All directions provided are from the reference point of the mower seat facing the steering wheel. All left and right references are from this viewpoint.

For reference, please fill in the information below. This will assist your dealer in providing service for this ROPS. It is advisable that this information be provided to your insurance company as well in the event that the mower is lost or damaged.

Vehicle Model: _____

ROPS Serial Number: _____

Date of Purchase: _____

Dealer Name: _____



Tektite Limited Warranty

Tektite Manufacturing Inc. (“Tektite”) warrants to the original purchaser (the “Claimant”), that Tektite products will be free from defective materials or workmanship, under normal use and service, for a period of (1) full year from the original invoice date. Tektite’s liability under this Limited Warranty is limited to the repair or (at the discretion of Tektite) the replacement of those components of its products, which were manufactured by Tektite that are defective in materials or workmanship. Tektite shall have no liability under this Limited Warranty unless Tektite is notified of the defect during the stated Warranty Period.

Limitations and Exclusions: Tektite has no responsibility to a Claimant under this Limited Warranty or on any other basis for any of the following:

- a) defects caused, in whole or in part, by accident or misuse, negligence or failure to maintain the product or component.
- b) products or components sold to a customer on an “as is” basis.
- c) wiper blades, light bulbs, fuses, clear vinyl or other consumables.
- d) glass where the point of failure has not been preserved intact and delivered to Tektite for analysis of the cause of the failure.
- e) products or components which have been modified after shipping from Tektite to its customer.
- f) transportation charges for returned, repaired or replacement items.
- g) defects that are subject of a Tektite initiated recall where the Claimant fails to comply with the terms of the recall notice that comes to the attention of the Claimant.
- h) components of Tektite products that are manufactured by third parties (Tektite’s only obligation in relation to such components shall be to accord to the Claimant the benefit of any transferable warranty accorded to Tektite by third party manufacturer).
- i) defects in workmanship or materials in products or components that are repaired or replaced by Tektite unless Tektite is notified of the new defect within the Warranty Period that applied to the original product or component that has been repaired or replaced.
- j) defects that result, in whole or in part, from inadequate engineering or specifications provided to Tektite by its customer.
- k) any actual or alleged deficiency in technical or engineering services or advice provided by Tektite to its customer whether provided for valuable consideration or otherwise.
- l) consequential damages, or any other damages whether foreseeable or not, resulting from the defect or any delay in remedying the defect.
- m) any breach or alleged breach of any implied warranty of merchantability or fitness for particular purpose of use.
- n) defects or part failure due to misuse or failure to follow recommended cab installation procedures; and travel expenses, including mileage.

This Limited Warranty expresses the entire obligation of Tektite, its officers, directors, agents and employees, to its customer or any Claimant in respect of any defect in workmanship, or materials of any product or component sold or manufactured by Tektite whether on grounds of breach of contract, negligence or other tortious liability, breach of express or implied warranty or other basis in law of any jurisdiction.

Acceptance by a customer of delivery of products of Tektite constitutes acceptance of this Limited Warranty in lieu of all other warranties express or implied including without limitation all implied warranties of merchantability or fitness for particular purpose or use and constitutes acceptance by customer of the exclusions and limitations of the liability of Tektite set out above. Once received, the cab should have ALL exterior cardboard, Styrofoam wrapping removed for immediate inspection of product to ensure that no damages have occurred during transportation. Outer coverings should stay off the cab and the cab be stored indoors in a controlled environment. The warranty card must be completed and returned to Tektite.

Warranty claims should be reported to parts@tektite.ca. A warranty claim form and instructions will be provided at this time. Warranty work not pre-authorized by Tektite may not be covered by this warranty agreement. Labor rate and time allowances are fixed by Tektite. Approved warranty claims will be issued in the form of credits applied to customer account.



Safety Precautions

Safety First

Read these instructions carefully. It is essential that you read the instructions and safety regulations before you attempt to assemble or use the features that are on this cab/ROPS.

Danger: Indicates an immediate hazardous situation which, if not avoided, will result in death or serious injury.

Warning: Indicates a potentially hazardous situation which, if not avoided, may result in death or serious injury.

Caution: Indicates a potentially hazardous situation which, if not avoided, may result in minor or moderate injury.

Important: Indicates that cab or property damage may result if instructions are not carefully followed.

NOTE: All products are designed to give safe, dependable service if they are operated and maintained according to instructions. It is the owner's responsibility to be certain anyone operating this product reads this manual, and all other applicable manuals, to become familiar with this cab and all safety precautions. Failure to do so could result in serious personal injury or cab damage. If you have any questions, consult your dealer. Read and understand this manual before operation.

NOTE: A safe operator is the best assurance against accidents. All operators, no matter how experienced they may be, should read this operator manual and all other related manuals before attempting to operate features in this cab/ROPS and operate the base mower. Please read the following section and pay particular attention to all safety recommendations contained in this manual and those labelled on the cab and on the mower.



General Safety

1. Never let an unqualified or untrained driver operate the mower.
2. Keep a fire extinguisher, with ABC rating securely fastened in the ROPS. Maintain it and be familiar with its use.
3. Do not carry passengers.
4. Never operate the mower in a closed building for a prolonged period. Ensure adequate ventilation is present, as engine exhaust fumes are poisonous and can kill.
5. Always keep sleeves, jackets or other loose clothing relatively tight and belted. Loose clothing may catch on moving parts and result in severe personal injury or death.
6. Provide a first-aid kit, securely attached inside of the ROPS for use in case of accident.
7. Never jump from the mower. There is a danger of tripping or falling on protruding parts.
8. Use steps and hand holds when mounting and dismounting the mower, or for servicing components too high to reach from the ground.
9. When seated in the ROPS, fasten seat belt before starting the engine. A proper seat belt must be worn at all times when using a ROPS.
- 10 Safety devices and shields are intended to protect operators from injury or death. Under no circumstances should they be modified, disabled or removed.

Operating Safety

1. Always operate the mower controls while sitting in the operator's seat.
2. Lock seat in position and buckle seat belt before operating the mower.
3. Avoid abrupt sharp turns at high speeds.
4. On sloped terrain, do not make sharp turns as machine stability could be compromised.
5. Operate the mower smoothly, avoid abrupt starts and stops.
6. Keep all shields in place when operating the mower.
7. Do not operate the mower when you are tired, sick, or impaired.
8. Never operate the mower in confined areas; visibility next to the mower is reduced. Injury to bystanders or damage to the ROPS or equipment may result.

Safety

Carefully review the procedures given in this manual and the mower operator's manual with all operators annually. It is important that all operators become familiar with and follow safety precautions. Operating instructions must be given to everyone using the mower before operation and at least once yearly thereafter in compliance with OSHA Regulations 1928.57 (United States).



Safe Operation on Rough Terrain

1. Drive the mower slowly on hillsides and curves to eliminate the danger of tipping. Avoid slopes which are too steep for safe operation. Avoid sharp uphill turns.
2. Always drive slowly enough over rough ground or obstructions. Drive at speeds slow enough to ensure your safety.
3. When driving out of a ditch, gully, or up a steep hillside, engage the clutch slowly. Avoid sharp uphill turns.
4. When descending steep grades, select a sufficiently low gear to maintain control with minimum use of braking.
5. Use caution when driving near the edge of a ditch or gully. It may cave in, causing the mower to roll over.
6. Be alert when operating near trees, slopes and around obstructions. Tree branches can cause damage to ROPS components.

Maintenance Safety

1. Remove mud, crop residue, chains, and tools from steps and operator's platform. They may interfere with pedal operation or entry/exit from mower.
2. When servicing components are too high to reach from the ground use steps and handholds. Do not use fenders or shields that are not designed as steps.

Safe Highway Operation

1. Before operating the mower on, or near, public roadways check with your local authorities for any local regulations that will affect you.
2. Equip towed implements with slow moving vehicle (SMV) signs when traveling on public roads.
3. Install additional lights on implement rear to safeguard against rear end collisions.
4. Use hazard warning flashers as required by law when transporting or driving on public roads. If the mower had warning flashers removed when mounting the ROPS, they must be replaced prior to operation on public roads.
5. Keep to the right, yielding right-of-way traffic, especially if pulling implements. Pull off the road and stop to allow motorists to pass. Drive on the road shoulder, if permitted by law.
6. Use extreme caution when pulling heavy loads at road speeds. Avoid hard application of the mower brakes at high speed.
7. Always drive slowly near curbs, approaches or ditches.



8. If equipped, ensure headlights are aligned so they will not blind the operators of oncoming vehicles. If the mower is not equipped with turn signals and law requires them, install them prior to operating on or near public roads.
9. Use your turn signals, checking for traffic well in advance of turning. If the mower is not equipped with turn signals and law requires them, install them prior to operating on or near public roads.

Safety Decals

1. Keep decals clean. Remove dirt with a wet clean cloth when necessary.
2. Replace safety decals if destroyed, missing, painted over or unreadable. If any safety decals are covered or obscured when the ROPS is mounted, it is recommended that you purchase replacement decals from the mower manufacturer. Mount them in a readable location at, or near, their original location before operating the mower.
3. New ROPS decals and mower decals are available from your mower dealer.

ROPS Safety

1. Install the ROPS in accordance with Tektite mounting instructions. Failure to do so may affect the ROPS ability to withstand a roll over.
2. If the ROPS is subjected to alteration, structural damage or involved in an overturn accident, the entire structure must be replaced. Failure to do so may result in injury or death in the event of a roll over.
3. If the mower is not equipped with seat belts, purchase approved seat belts from the mower manufacturer or Tektite prior to operating the mower.
4. Always fasten seat belts prior to operating the mower.
5. Always operate the mower from the operator's seat.
6. Remove mud, crop residue, chains and tools from steps and operator's platform. They may interfere with pedal operation or entry/exit from the mower.
7. Remove all loose chains, tools, and equipment from the operator's platform. Failure to do so may cause injury or death in the event of a roll over.
8. Do not install the ROPS on a mower model that the ROPS is not designated for (compatible mower designations are printed on the ROPS serial number plate). The ROPS is designed specifically for individual models to ensure ROPS requirements will be met. Installing the ROPS on a non designated mower may result in injury or death.

Emergency Exits

This ROPS cab has 2 exits, which may be used in an emergency: left and right doors.



Operating Instructions

Important

The following section locates, identifies and briefly describes the functions of all cab controls. All operators should familiarize themselves with control location and function prior to operating the mower. Failure to do so may result in unsafe operation of the mower and possible injury or death to operators and bystanders.

There are two switch plates located in the headliner. The following switches are available, and their functionality is described.

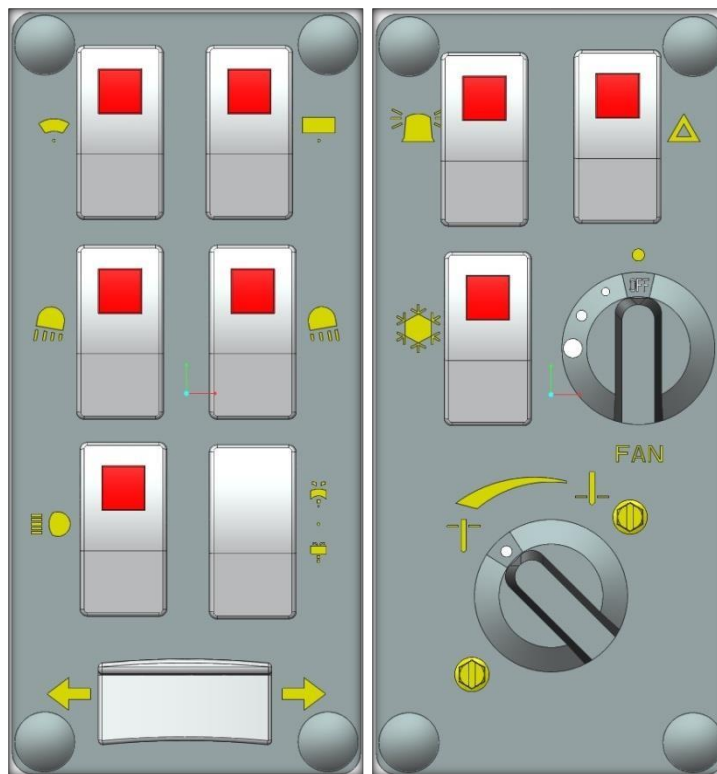

Left Switch Plate

1. Front Wiper Rocker Switch (standard)

Low position: Off

High position: On

Note: indicator light activates when wiper is on.



2. Rear Wiper Rocker Switch (optional)

Low position: Off

High position: On

Note: indicator light activates when wiper is on.

3. Front Work Light Rocker Switch (optional)

Low position: Off

High position: On

Note: indicator light activates when work lights are on.

4. Rear Work Light Rocker Switch (optional)

Low position: Off

High position: On

Note: indicator light activates when work light is on.

5. Head Lights Rocker Switch (optional)

Low position: Off

High position: On

Note: indicator light activates when head lights are on.

6. Front and Rear Washer Rocker Switch (optional)

Low position: Momentary – On Rear Washer

Middle position: Off

High position: Momentary – On Front Washer

7. Turn Signal Rocker Switch (optional)

Left position: On

Middle position: Off Right position: On

Right Switch Plate

1. Beacon Rocker Switch (standard)

Low position: Off

High position: On

Note: indicator light activates when beacon is on.



2. Hazard Rocker Switch (optional)

Low position: Off

High position: On

Note: indicator light activates when 4-way flashers are on.

3. Air Conditioner Rocker Switch (optional)

Low position: Off

High position: On

Note: indicator light activates when air conditioner is on.

4. Fan Rotary Switch (optional)

Indicator mark above switch indicates whether fan is operational or not and which speed has been selected.

5. Temperature Control Rotary Switch (optional)

Indicator mark in upper left-hand quadrant indicates flow volume of coolant through the heater core. Turned left to maximum is maximum heat output. Turned right means valve has been closed and no coolant will be flowing through the heater core.

Cab Circuit Protection

The Tektite ROPS cab is wired to provide maximum protection against accidental battery rundown and circuit overload. A relay in the cab is ignition activated and prevents the operator from accidentally leaving fan motors, lights on after turning the mower off and leaving for the day. A circuit breaker is provided to prevent the cab electrical components from drawing more power than they should be able to from a dead short. The cab electrical components are also fused individually, and the fuse block is in the headliner, directly above the door opening on the left side. Locate the 3" snap cap, and with a small flat screwdriver you can remove the cap to examine the fuses provided. A decal on the fuse block indicates which fuse is for which electrical option.

After your ROPS Cab has been installed:

Before starting a mower equipped with a Tektite ROPS cab:

1. Clear the operator platform of all tools. Tools left in or around the ROPS and mower can cause operator interference which could lead to bodily injury and/or damage the machine.



2. Inspect the ROPS and mower to ensure all bolts are tight and re-tighten if required.
3. Ensure that all pedals, levers, and controls have adequate clearance for normal operation.
4. Ensure that all electrical components of both the ROPS and mower operate normally.
5. Ensure your door latches properly onto the striker pin. Immediately after installation, the ROPS frame may flex slightly from installation, and the door latch will need to be re-aligned for proper operation. Loosen the striker pin, striker mounting plate and door latch as necessary to get a proper alignment of the door striker.

Service Parts Breakdowns:

Following are parts breakdowns for components that may require service parts replacement during the life of the ROPS. If you require replacement parts, please contact the dealer that you purchased the ROPS from and indicate which parts you require.